

# 1: Housing components (カバー関係)

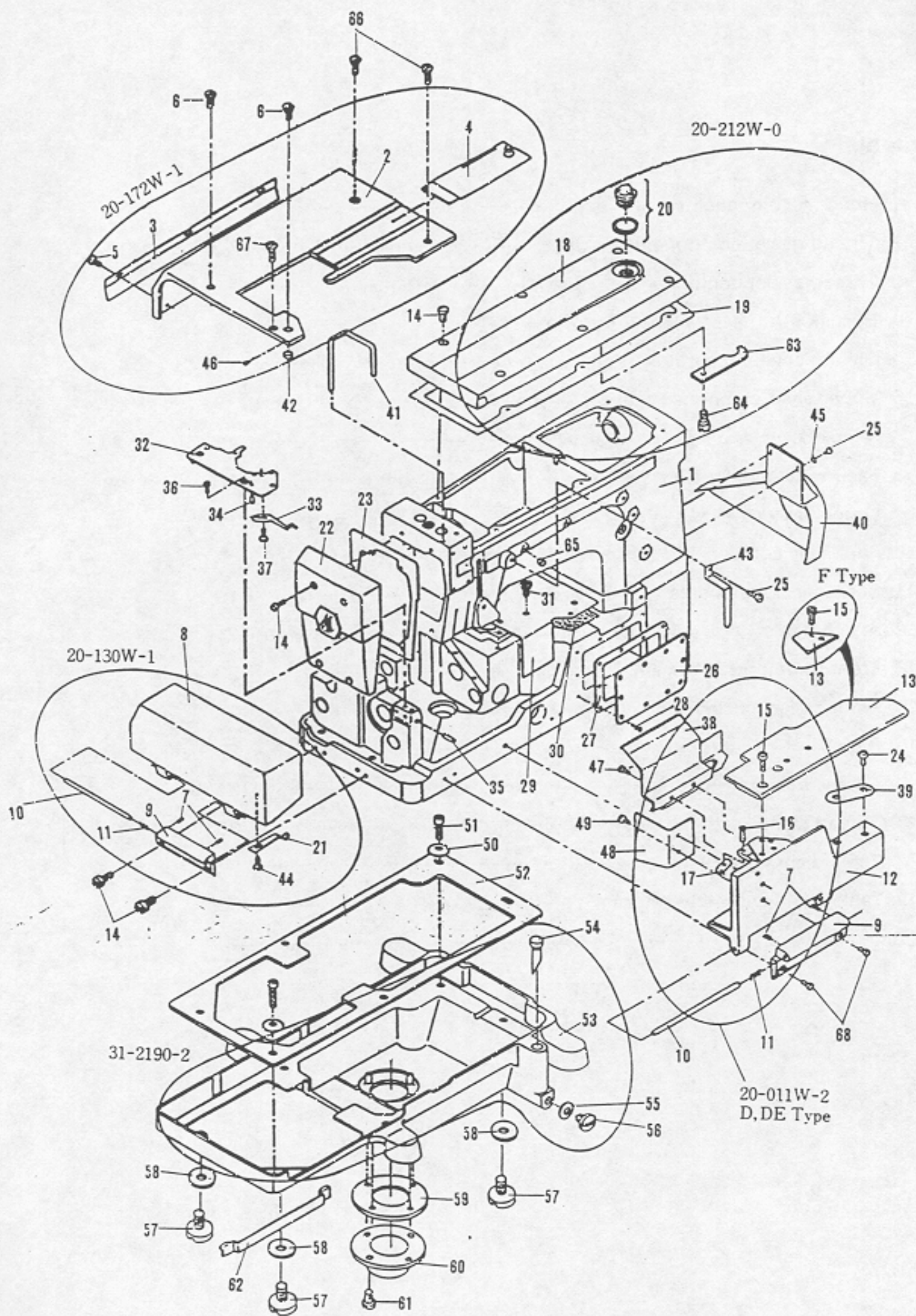

From the library of: Diamond Needle Corp

No.	Par No.	Part name	品 名	D	DE	F	EMK
1	22-872W-0	Arm bed set	アームベットセット	1	1	1	
	22-883W-0	Arm bed set	アームベットセット				1
2	21-7210-0	Upper cloth plate	上ベースカバー	1	1	1	
3	21-4430-0	Supporting cover	上ベース補助カバー	1	1	1	1
4	21-5210-0	Slide plate	差板	1	1	1	1
5	84-5740-0	Screw	ネジ	3	3	3	3
6	84-8620-0	Screw	ネジ	2	2	2	2
7	84-3140-0	Screw	ネジ	4	4	4	21
8	21-352W-0	Slide cover	横ベースカバーC	1	1	1	
9	25-108W-0	Hinge	定規台取付ヒンジ	2	2	2	1
10	71-3080-0	Hinge pin	ヒンジピン	2	2	2	1
11	79-2330-0	Spring	取付巻バネ	2	2	2	1
12	21-183W-0	Ruller holder A	定規台	1	1	1	
13	21-192W-0	Ruller plate A	定規板	1	1		
	21-1910-0	Ruller plate	定規板			1	
14	84-5660-0	Screw	ネジ	10	10	10	10
15	84-5720-0	Screw	ネジ	2	2	2	2
16	84-4620-0	Screw	ネジ	2	2	2	2
17	71-4010-0	Setting pin for ruller holder spring	定規台裏バネピン	1	1	1	1
18	21-212W-0	Crank chamber oil cover	立ロットカバー	1	1	1	1
19	23-8030-0	Crank chamber oil cover packing	立ロットカバーパッキン	1	1	1	1
20	39-2330-0	Oil pot lid	オイルポット	1	1	1	1
21	79-5020-0	Spring	横ベースカバー板バネ	1	1	1	1
22	20-805W-0	Head cover	面 板	1	1	1	1
23	23-2390-0	Head cover gasket	面板パッキン	1	1	1	1
24	85-1810-0	Screw	ネジ	2	2	2	2
25	84-5710-0	Screw	ネジ	5	5	5	5
26	21-122G-0	Oil reservoir front cover	前油カバー	1	1	1	1
27	23-2340-0	Oil reservoir front cover gasket	前油カバーパッキン	1	1	1	1
28	84-6640-0	Screw	ネジ	8	8	8	8
29	21-4980-0	Oil reservoir top cover	上油カバー	1	1	1	1
30	23-2290-0	Oil reservoir top cover gasket	上油カバーパッキン	1	1	1	1
31	84-6610-0	Screw	ネジ	5	5	5	5
32	14-0310-2	Needle plate support	針板土台	1	1	1	1
33	79-5010-0	Ruller holder spring	定規板板バネ	1	1	1	1
34	71-2510-0	Knock pin	針板ノックピン	2	2	2	2
35	71-3010-0	Pin	横ベースカバー板バネピン	1	1	1	1
36	84-7610-0	Screw	ネジ	2	2	2	4
37	84-3610-0	Screw	ネジ	2	2	2	2
38	21-1000-0	Oil cover	オイルフェンス	1	1	1	1
39	26-7120-0	Folder base bracket	ラッパ取付台	1	1	1	1
40	21-4020-0	Pulley cover	プーリーカバー	1	1	1	
41	21-7030-0	Needle bar eyelet safety bar	針棒糸道保護バーC	1	1	1	1
42	71-1190-0	Ruller plate stopper	定規台ストッパー	1	1	1	
43	21-7120-0	Needle lever eyelet safety plate	弓糸道保護バー	1	1	1	1
44	84-5710-0	Screw	ネジ	1	1	1	
45	75-4550-0	Washer	ワッシャ	2	2	2	2
46	25-8010-0	Cushion	2枚カバー防振ゴム	3	3	3	5
47	84-5640-0	Screw	ネジ	2	2	2	
48	21-1850-0	Side cover	定規台サイドカバー	1	1	1	
49	84-3640-0	Screw	ネジ	2	2	2	
50	75-4520-0	Washer	ワッシャ	2	2	2	2
51	85-6280-0	Screw	ネジ	2	2	2	2
52	23-1590-0	Packing	オイルタンクパッキン	1	1	1	1
53	31-2190-2	Oil tank set	オイルタンクセット	1	1	1	1
54	39-2160-0	Oil gauge E	オイルゲージE	1	1	1	1
55	23-3040-0	Drain seai	オイルタンクドレンシール	1	1	1	1
56	87-3110-0	Screw	ネジ	1	1	1	1
57	85-2200-0	Screw	ネジ	4	4	4	4
58	23-1200-0	Oil tank Packing	オイルタンクパッキン	4	4	4	4
59	23-9130-0	Oil filter Packing	オイルフィルター受パッキン	1	1	1	1
60	35-9150-0	Oil filter plate	オイルフィルター受	1	1	1	1
61	84-7630-0	Screw	ネジ	4	4	4	4
62	39-1670-0	Oil fence	オイルタンク用フェンス	1	1	1	1
63	39-1370-0	Tubu support B	配管B用サポート	1	1	1	1
64	84-1610-0	Screw	ネジ	1	1	1	1
65	23-1750-0	Gom	ゴム	1	1	1	1
66	84-8610-0	Screw	ネジ	2	2	2	2
67	84-6640-0	Screw	ネジ	1	1	1	
68	84-5710-0	Screw	ネジ	2	2	2	2

From the library of: Diamond Needle Corp



## 2. Thread eyelet components (糸道関係)

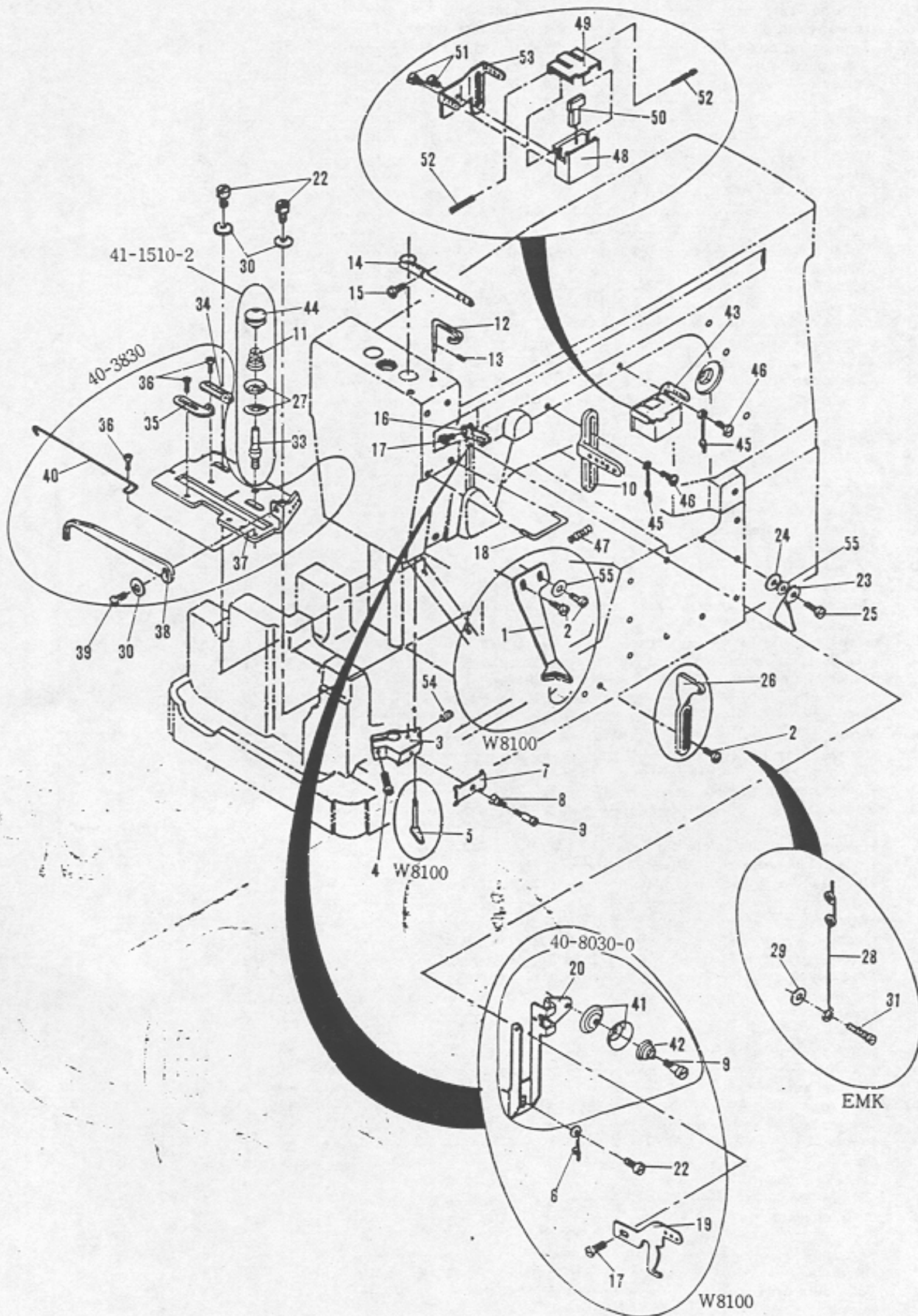

From the library of: Diamond Needle Corp

No.	Part No.	Part name	品 名	V7100	W8100
1	45-9230-0	Zigzag thread eyelet	糸道D		1
2	84-3610-0	Screw	ネジ	2	4
3	41-3040-1	Nipper bracket	針株クランプ糸道台	1	1
4	84-4130-0	Screw	ネジ	1	1
5	45-9140-0	"L"Thread eyelet	L型糸道		1
6	47-1490-0	Upper thread guide eyelet	上糸案内糸道		1
7	45-1420-0	Tension nipper	カメ糸道B	1	1
8	41-7210-0	Tension nipper spring	カメ糸道押しバネ	1	1
9	84-1710-0	Screw	ネジ	1	2
10	45-0810-0	Needle thread eyelet	上糸糸道W3	1	1
11	41-1530-0	Spring	バネ	1	1
12	45-2510-0	Needle thread take-up wire	上糸受け	1	1
13	84-5210-0	Screw	ネジ	1	1
14	45-1810-0	Needle bar thread eyelet	針株糸道	1	1
15	84-3610-0	Screw	ネジ	1	1
16	45-0910-0	Needle thread retainer eyelet	上糸捌き糸道	1	
17	84-5740-0	Screw	ネジ	1	1
18	45-2460-0	Guide pin	上糸ガイドピン	1	1
19	45-0960-0	Needle lever thread eyelet	上糸テンピン捌き糸道		1
20	45-0940-0	Covering looper thread eyelet	上糸捌き調節糸道		1
22	84-5740-0	Screw	ネジ	1	1
23	41-4160-0	Looper thread eyelet	12本針糸立て糸道		1
24	23-1870-0	O-ring	Oリング	1	1
25	84-3740-0	Screw	ネジ	1	1
26	45-1000-0	Looper thread eyelet	上糸糸道(上)	1	1
27	41-1550-0	Tension nipper	捌き用小チャンポン皿	2	2
28	47-2020-0	Looper thread eyelet (EMK)	糸案内糸道B (EMKノミ)	1	1
29	23-1870-0	O-ring (EMK)	Oリング (EMKノミ)	1	1
30	75-4680-0	Washer	ワッシャー	3	3
31	84-4130-0	Screw	ネジ (EMKノミ)	1	1
32	47-2030-0	Looper thread eyelet guide	下糸案内糸道C	1	1
33	41-1510-0	Looper thread guide tension stud	上糸チャンポン用調子棒	1	1
34	47-1320-0	Looper thread eyelet (left)	下糸捌き板案内糸道(左)	1	1
35	47-1310-0	Looper thread guide eyelet (right)	下糸捌き板案内糸道(右)	1	1
36	84-1610-0	Screw	ネジ	3	3
37	43-3420-0	Cast-off support bracket	下糸捌き板	1	1
38	43-3440-0	Looper thread retainer	下糸捌き上	1	1
39	84-3610-0	Screw	ネジ	1	1
40	43-3380-0	Looper thread retainer	下糸捌き下ピン	1	1
41	41-1560-0	Tension nipper	上飾り捌き小チャンポン皿		2
42	41-1570-0	Tension nipper spring	上飾り捌き調子バネ		1
43	20-532G-0	Selection tank set	シリコンタンクセット	1	1
44	41-1540-0	Nut	ナット	1	1
45	47-1440-0	Thread eyelet	糸道		2
46	84-5710-0	Screw	ネジ	2	2
47	73-2280-0	Spring	上糸ガイドバー用バネ	1	1
48	27-5310-0	Silicon tank	シリコンタンク	1	1
49	27-5330-0	Silicon tank lid	シリコンタンクフタ	1	1
50	27-5340-0	Felt	フェルト	1	1
51	84-1610-0	Screw	ネジ	2	2
52	71-2020-0	Pin	ピン	2	2
53	45-1690-0	Thread eyelet	糸道	1	1
54	84-1120-0	Screw	ネジ		1
55	75-4550-0	Washer	ワッシャー	1	2

From the library of: Diamond Needle Corp

### 3. Thread eyelet components (糸調子関係)

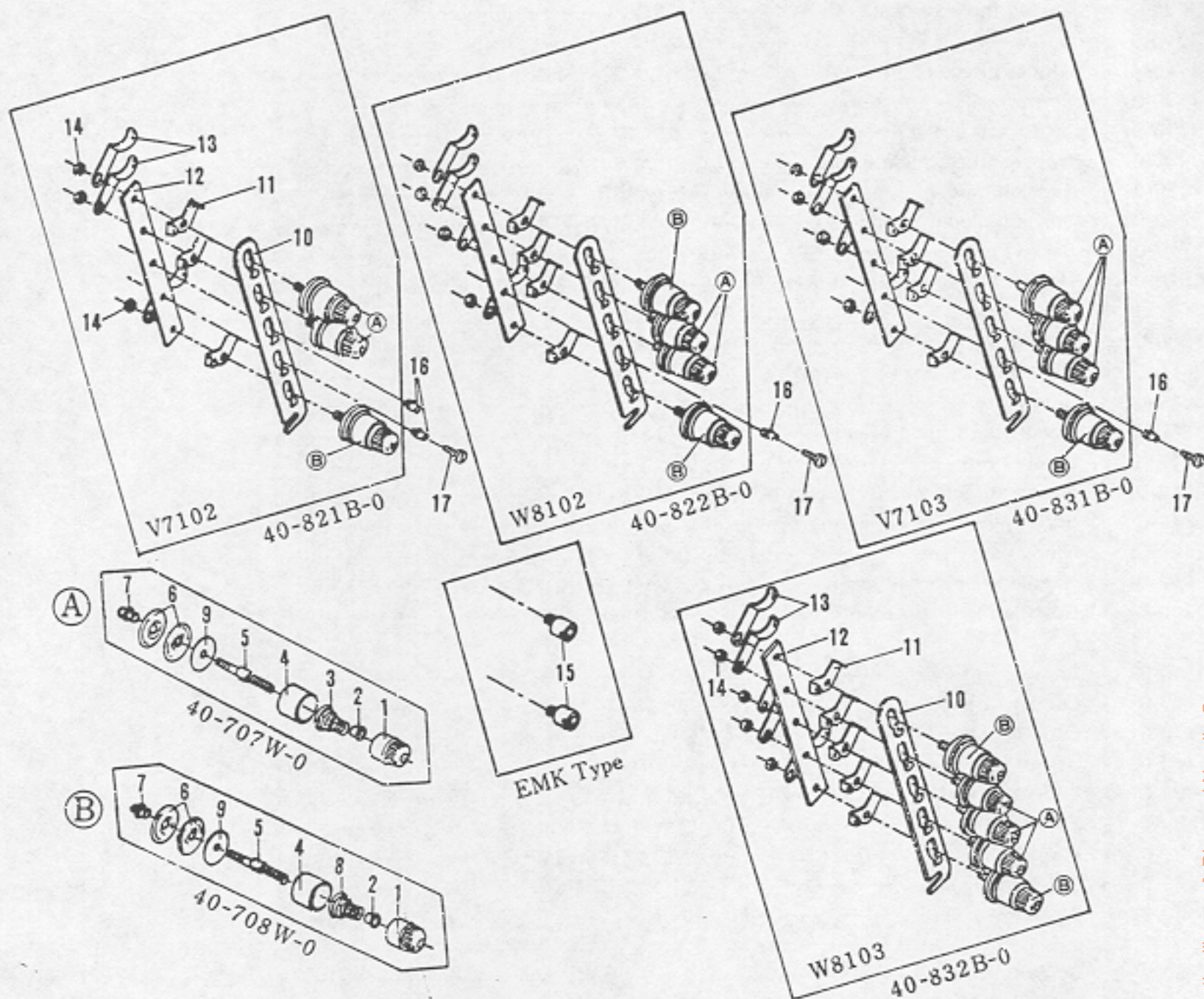

No.	Part No.	Part name	品名	W8103	W8102	V7103	V7102
1	41-101W-0	Adjusting nut	チャンボン皿小ケース	5	4	4	3
2	41-105W-0	Adjusting ratchet	チャンボン皿ラチェット	5	4	4	3
3	41-7010-0	Spring strong	チャンボン調子バネ強	3	2	3	2
4	41-107W-0	Disc cover	チャンボン皿大ケース	5	4	4	3
5	41-1720-0	Tension post	調子棒中	5	4	4	3
6	41-1110-0	Disc	チャンボン皿	10	8	8	6
7	41-1310-0	Collar	調子棒カラーA	5	4	4	3
8	41-7020-0	Spring weak	チャンボン調子バネ弱	2	2	1	1
9	23-3240-0	Felt	取付けフェルト	5	4	4	3
10	41-236B-0	Tension post support	チャンボン皿調節板	1	1	1	1
11	41-1150-0	Thread eyelet	糸道上	5	4	4	3
12	41-237B-0	Tension post holder	チャンボン元板	1	1	1	1
13	41-1170-0	Thread eyelet	糸道下	5	4	4	3
14	86-4110-0	Nut	ナット	5	4	4	3
15	01-8160-0	Screw EMK	チャンボン元板スペースネジ(EMKノミ)	2	2	2	2
16	41-1320-0	Collar B	カラーB		1	1	2
17	84-7640-0	Screw	ネジ		1	1	2

#### 4. Bushings (ブッシュ関係)

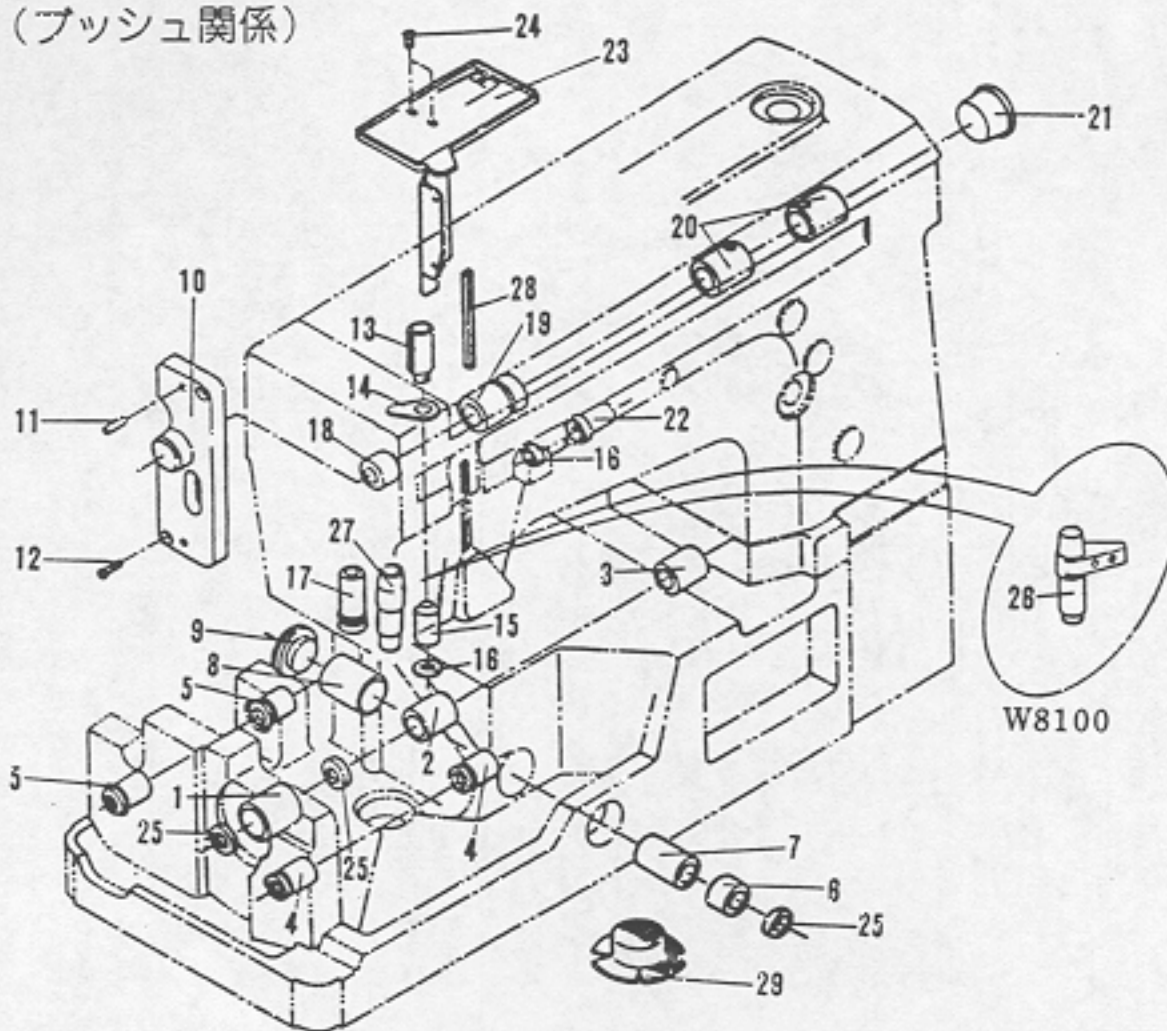

No.	Part No.	Part name	品名	V7100	W8100
1	81-7140-0	Bushing	下シャフトブッシュ (前)	1	1
2	81-7200-0	Bushing	下シャフトブッシュ	1	1
3	81-8070-0	Bushing	下シャフトブッシュ (後)	1	1
4	81-7350-0	Bushing	ルーバーシャフトブッシュ左B	2	2
5	81-7530-0	Bushing	送り台シャフトブッシュ	2	2
6	81-2390-0	Bushing	ルーバー振元シャフトブッシュ	1	1
7	81-2360-0	Bushing	ルーバー振元シャフトブッシュ	1	1
8	81-2370-0	Bushing	振元シャフトブッシュC	1	1
9	23-2960-0	Seal.cap	上シャフトシールキャップ	1	1
10	69-8030-0	Bushing support	ブッシュサポート	1	1
11	71-2160-0	Pin	ルーバーアジャストピン	2	2
12	84-7630-0	Screw	ネジ	2	2
13	81-2060-0	Bushing	針棒ブッシュ	1	1
14	39-8010-0	Oil fence	針棒オイルフェンス	1	1
15	81-2090-0	Bushing	針棒ブッシュ	1	1
16	94-2310-0	Oil seal	シャフトシール	2	2
17	81-1490-0	Bushing	上飾り土台ブッシュ		1
18	81-8030-0	Bushing	上シャフトベッドブッシュ	1	1
19	81-0810-0	Bushing	上シャフトブッシュ	1	1
20	81-0820-0	Bushing	上シャフトブッシュ	2	2
21	23-8000-0	O-ring	Oリング	1	1
22	81-8080-0	Bushing	アームクランクブッシュ	1	1
23	39-8030-0	Oil fence	天秤オイルフェンス	1	1
24	84-4620-0	Screw	ネジ	2	2
25	94-2140-0	Oil seal	オイルシール	3	3
26	81-1620-0	Bushing W8100	押工棒ブッシュ		1
27	81-1630-0	Bushing W7100	押工棒ブッシュ	1	
28	39-8060-0	Rubber	オイルフェンスゴム	1	1
29	31-4380-0	filter	ベツフィルター	1	1

# 5. Oil lubrication apparatus (給油機構)

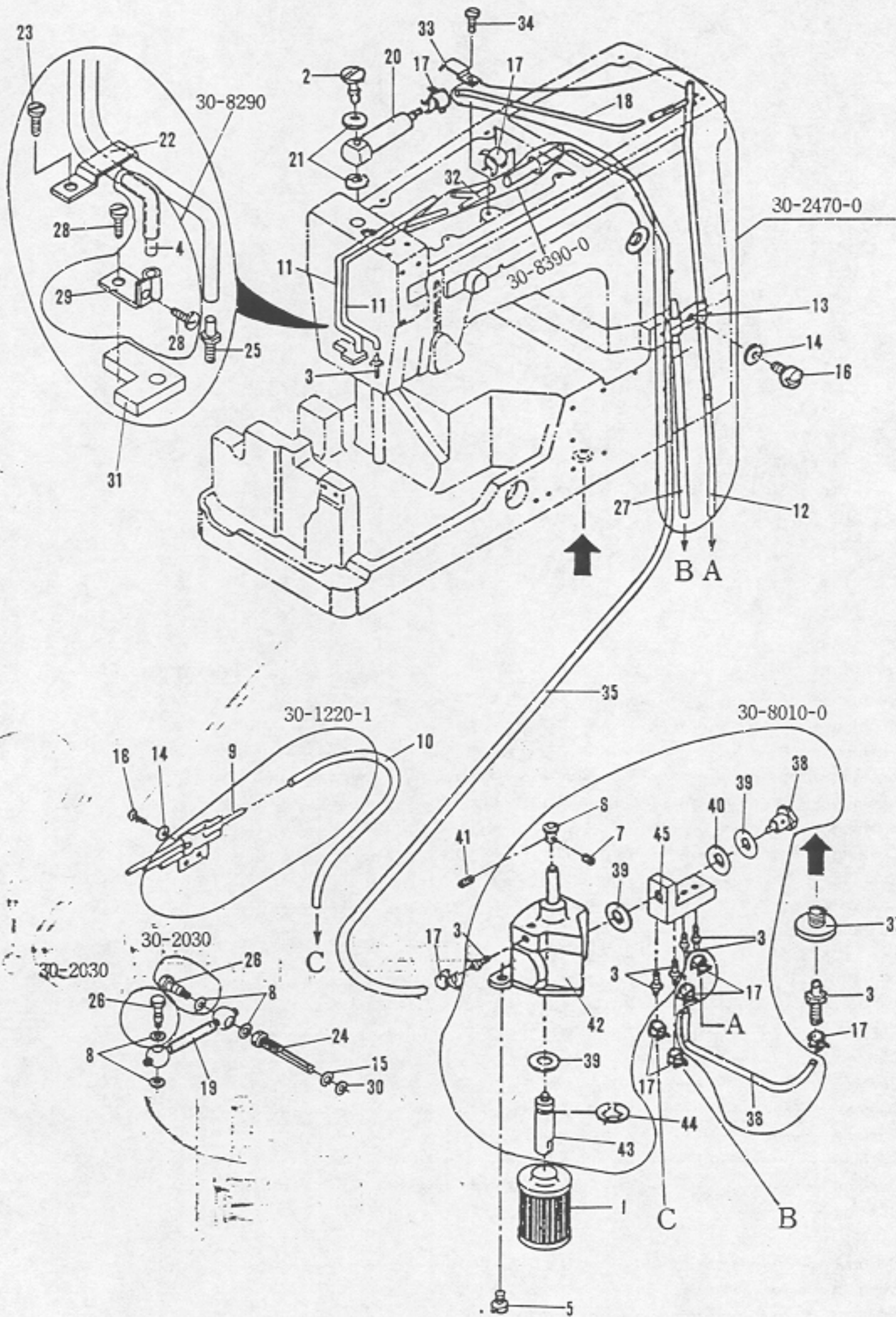

From the library of: Diamond Needle Corp

No.	Part No.	Part name	品 名	Q, ty
1	31-2220-0	Oil filter	オイルフィルター	1
2	35-3320-0	Oil splash screw	上シャフト配管ジョイントネジ	2
3	31-3140-0	Pipe joint	ビニールパイプ継手C	3
4	35-8290-0	Pipe	面板オイルバックパイプ	1
5	84-5660-0	Screw	ネジ	2
6	31-4090-0	Gear	ポンプウォーム歯車	1
7	84-5210-0	Screw	ネジ	1
8	23-9110-0	Oil tube Washer	ワッシャ	4
9	35-1220-0	Pipe	セバレート配管	1
10	35-3150-0	Vinyl pipe (190ℓ)	ビニールパイプ大 190ℓ	1
11	35-3240-0	Vinyl pipe (250ℓ)	ビニールパイプ小 B (250ℓ)	2
12	35-3170-0	Vinyl pipe (290ℓ)	ビニールパイプ台 (290ℓ)	2
13	35-2470-0	Piping	立てロット用配管 B	1
14	23-1600-0	Seal	配管油止シール	3
15	75-4700-0	Drain seal	オイルタンクドレンシール	1
16	84-3670-0	Screw	ネジ	3
17	35-4120-0	Pipe support	配管チューブ止金具	5
18	35-3140-0	Vinyl pipe 125ℓ	ビニールパイプ大 125ℓ	1
19	30-5000-0	Felt	Rフェルト	1
20	35-8310-0	Vinyl tube coupling	上シャフト配管ジョイント	1
21	23-3060-0	Packing	配管油止シール	4
22	39-1380-0	Pipe support E	パイプサポートE	1
23	84-3610-0	Screw	ネジ	3
24	35-2040-1	Oil flow screw	オイルフォローネジ	1
25	31-3640-0	Pipe	ビニールパイプ継手E	1
26	35-2030-0	Oil guide screw	送り台オイル案内ネジB	2
27	35-3410-0	Vinyl tubu (240ℓ)	ビニールチューブ (240ℓ)	1
28	84-3610-0	Screw	糸道カバー止メネジ	2
29	35-1610-0	Pipe bracket	パイプ取付金具	1
30	23-1640-0	Pomp tube joint seal	ポンプチューブジョイントシール	1
31	23-3430-0	Oil back felt	オイルバックフェルト	1
32	35-8390-0	Oil back joint	オイルバックジョイント	1
33	39-1390-0	Pipe support	パイプサポート	1
34	84-5740-0	Screw	カバー止メネジ	1
35	35-3180-0	Vinyl tubu (440ℓ)	ビニールチューブ (440ℓ)	1
36	35-3430-0	Vinyl tubu (80ℓ)	ビニールチューブ (80ℓ)	1
37	85-5310-0	Screw	上糸道取付ネジ	1
38	35-8220-0	Screw	ポンプ配管ネジ	1
39	75-4700-0	Washer	ドレンワッシャB	3
40	23-1640-0	Pomp tubu joint seal	ポンプチューブジョイントシール	1
41	84-5110-0	Screw	針止メネジ	1
42	30-0150-0	Pomp set	ポンプセット	1
43	35-1070-0	Filter tubu	フィルター用吸口	1
44	93-2230-0	Ering	Eリング	1
45	31-2490-0	Oil separator	オイルセパレータ	1



# 6. Upper shaft components (上シャフト機構)

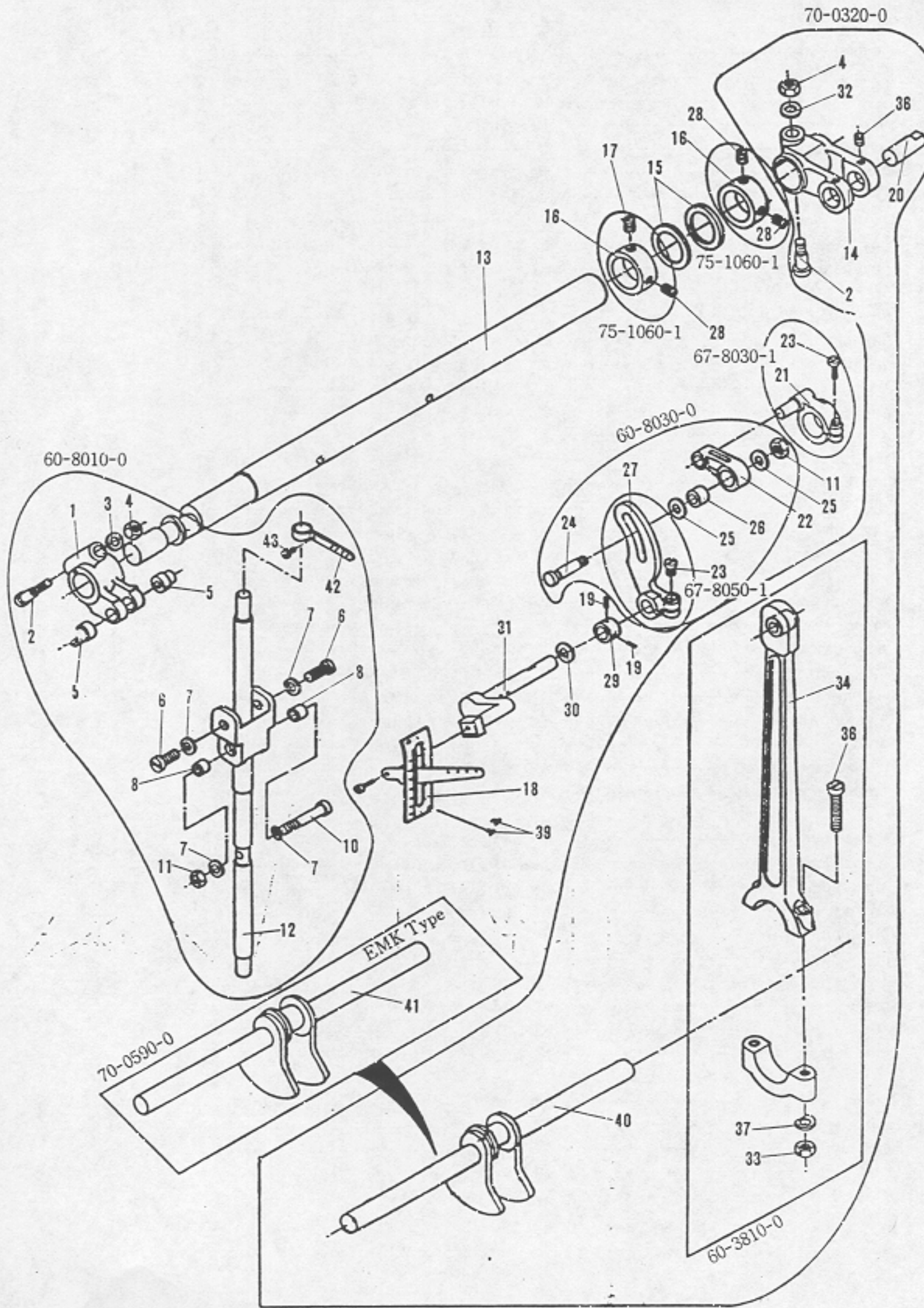

From the library of: Diamond Needle Corp

No.	Part No.	Part name	品名	Q, ty
1	67-8010-0	Needle bar crank lever	針棒クランクレバー	1
2	71-4550-0	Thread pin	立ロット連結レバー止ピン	2
3	75-3810-0	Washer	ワッシャ	2
4	86-5010-0	Nut	ナット	2
5	71-5010-0	Upper pin	針棒連結リンクピン	2
6	84-4010-0	Screw	ネジ	2
7	75-5220-0	Washer	ワッシャ	4
8	75-2490-0	Lever bush	針棒リンクローラー	2
9	66-8020-0	Needle bar joint	針棒連結リンク	1
10	84-6170-0	Screw	ネジ	1
11	86-3110-0	Nut	ナット	2
12	11-8010-0	Needle bar	針棒	1
13	71-6930-0	Upper shaft C	上シャフトC	1
14	67-8020-0	Crank lever	立ロット連結レバー	1
15	75-3060-0	Washer	ワッシャ	2
16	75-1060-0	Collar	カラー	2
17	85-2130-0	Screw	ネジ	1
18	24-1030-0	Plate	目盛板B	1
19	84-5110-0	Screw	ネジ	2
20	71-5060-0	Pin	ピン	1
21	67-8030-1	Thread tension lever	上糸捌き駆動レバー	1
22	66-8010-0	Thread tension regulating link	上糸調節連結リンク	1
23	84-8140-0	Screw	ネジ	2
24	84-5990-0	Screw	ネジ	1
25	75-5220-0	Washer	ワッシャ	2
26	75-2480-0	Roller	ローラー	1
27	67-8050-0	Thread tension regulating lever	上糸調節レバー	1
28	85-1130-0	Screw	ネジ	2
29	75-1520-1	Collar	カラー	1
30	75-3560-0	Washer	ワッシャ	1
31	69-8010-0	Arm crank	アームクランク	1
32	75-5520-0	Washer	ワッシャ	1
33	86-3150-0	Nut	ナット	2
34	60-3810-0	Crank rod	針棒クランクロッド	1
35	84-5210-0	Screw	ネジ	2
36	84-6210-0	Screw	ネジ	2
37	75-3980-0	Washer	ワッシャ	2
38	84-5740-0	Screw	ネジ	1
39	93-7010-0	Pin	ピン	2
40	71-8870-0	Crank shaft	クランクシャフト	1
41	71-8890-0	Crank shaft	クランクシャフト(EMK)	1
42	45-1810-0	Needle bar thread eyelet	針棒糸道	1
43	84-3610-0	Screw	ネジ	1

From the library of: Diamond Needle Corp

# 7. Needle lever crank (弓・クランク機構)

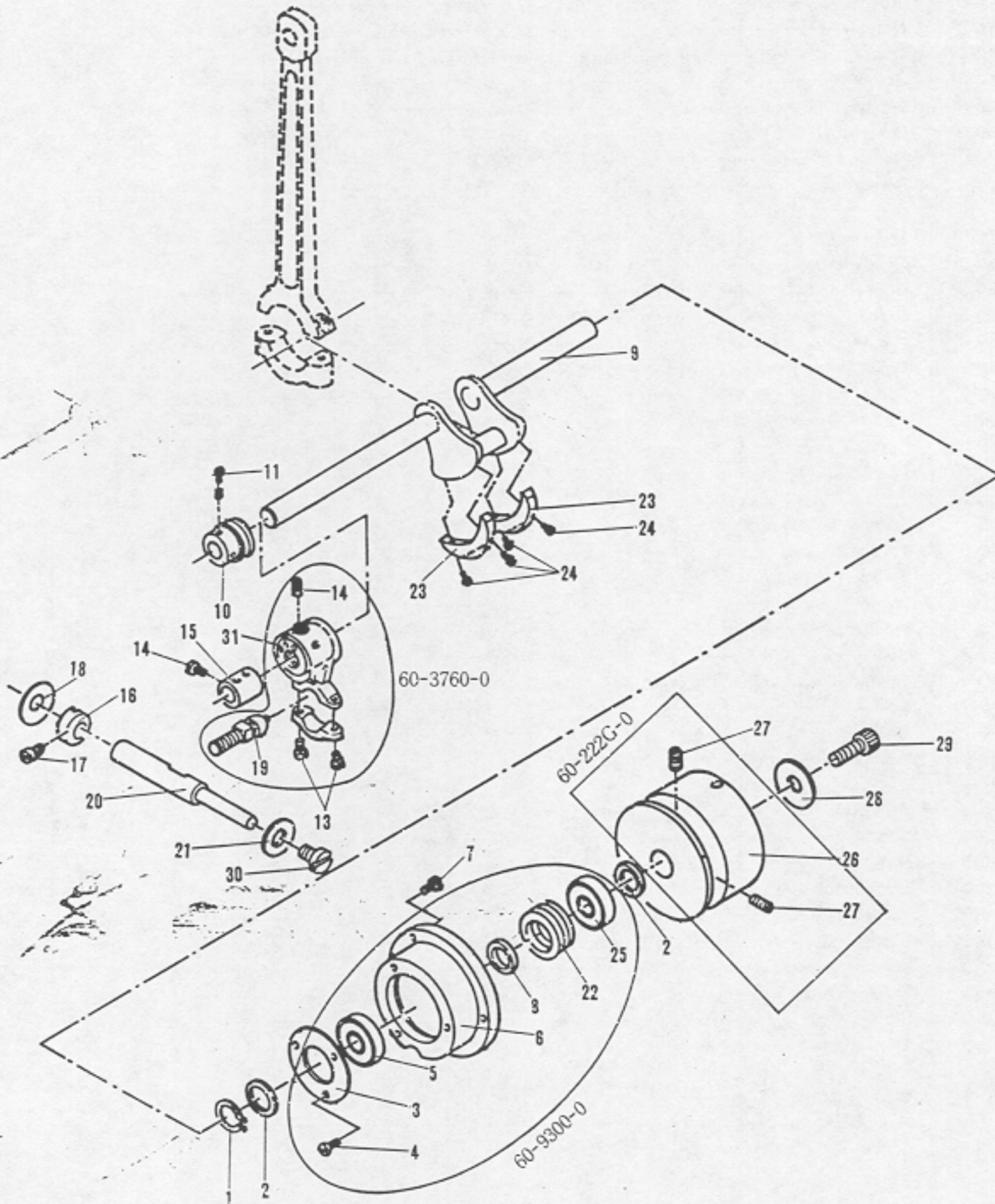

From the library of: Diamond Needle Corp

No.	Part No.	Part name	品 名	V.W	EMK
1	94-8100-0	C-ring	スナップリング	1	1
2	75-8140-0	Washer	ベアリングスラストワッシャ	2	2
3	69-1530-0	Set plate for bearing	ベアリング止板	1	1
4	84-5630-0	Screw	ネジ	3	3
5	91-9020-0	Bearing	ベアリング	1	1
6	69-3110-0	Flange	フランジ	1	1
7	84-5660-0	Screw	ネジ	3	3
8	75-1600-0	Collar	ベアリングスペースカラー	1	1
9	71-8870-0	Crank shaft	クランクシャフト	1	
10	31-4100-0	Worm gear	ポンプウォームホイール	1	1
11	84-7180-0	Screw	ネジ	2	2
12	67-3760-U	Looper driving lever ball joint	ルーバー振元ロッド	1	1
13	84-5720-0	Screw	ネジ	2	2
14	85-1130-0	Screw	ネジ	8	8
15	75-1010-0	Collar	クランクジョイントカラー	1	1
16	75-1070-1	Collar	ルーバー振元カラー	1	1
17	85-2120-0	Screw	ネジ	1	1
18	75-3220-0	Washer	ルーバー振元軸スラストワッシャ	1	1
19	61-7130-U	Looper driving eccentric	ルーバー振元ロッド玉	1	1
20	71-6130-0	Looper driving shaft B	ルーバー振元シャフトB	1	1
21	75-3320-0	Washer	メインシャフトワッシャ	1	1
22	79-0600-0	Spring	フランジ皿バネ	4	4
23	69-1470-0	Balance	クランクシャフトバランスウェイト	2	2
24	84-5710-0	Screw	ネジ	4	4
25	91-9030-0	Bearing	ベアリング	1	1
26	69-222G-0	Pulley	プーリー	1	1
27	85-1140-0	Screw	ネジ	2	2
28	75-1830-0	Washer	プーリースラストワッシャ	1	1
29	67-2630-0	Bolt M8	M8ボルト	1	1
30	84-5740-0	Screw	ネジ	1	1
31	61-5140-0	Eccentric	エキセントリック	1	1

From the library of: Diamond Needle Corp

# 8. Feed rocker (送り台機構)

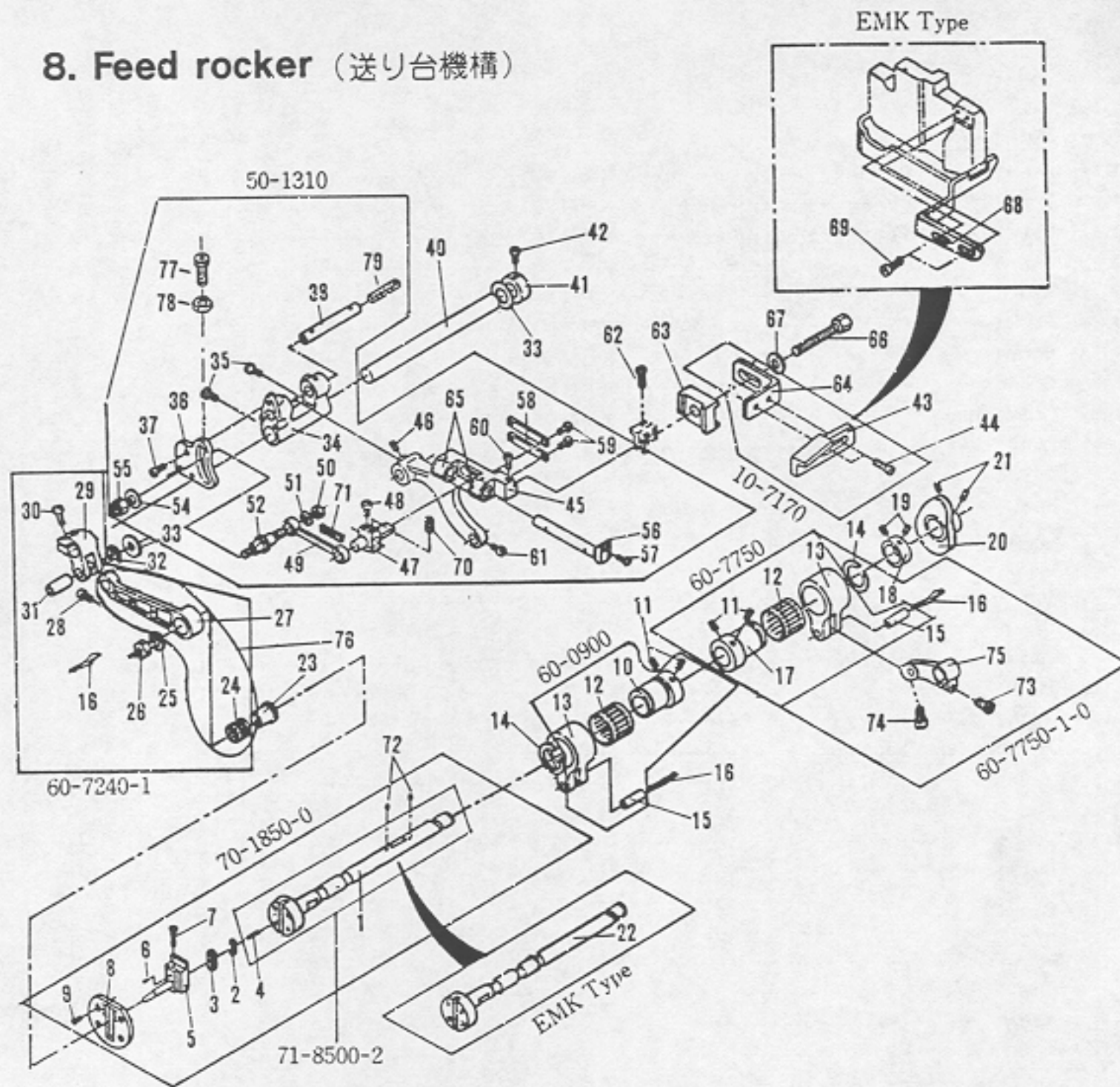

No.	Part No.	Part name	品名	V,W	EMK
1	71-7850-0	Main shaft 8E	前下シャフト8E	1	
2	51-0360-0	Oil guard	送り調節芯棒オイルガード	1	1
3	23-1970-0	O-ring	O-リング	1	1
4	23-3930-0	Felt	フェルト	1	1
5	51-0130-0	Feed crank adjusting post C	送り調節芯棒 (C)	1	1
6	85-6240-0	Screw	ネジ	1	1
7	84-3830-0	Screw	ネジ	1	1
8	51-0310-0	Main shaft plate	メインシャフトプレート	1	1
9	84-6610-0	Screw	ネジ	4	4
10	61-3220-0	Feed eccentric	送りエキセン玉	1	1
11	84-5210-0	Screw	ネジ	4	4
12	91-4060-0	Bearing	エキセンダルマ	2	2
13	63-2320-U	Eccentric link	エキセンダルマ	2	2
14	93-4060-0	Snap ring	サークリップ	2	2
15	71-4310-0	Connecting link pin	ダルマピン	2	2
16	23-3410-0	Felt	フェルト	3	3
17	61-3140-0	Looper avoid eccentric	針返しエキセン玉	1	1
18	75-1140-1	Collar	カラー	1	1
19	84-5110-0	Screw	ネジ	2	2
20	49-1390-1	Looper thread thread double disk	ハマグリ	1	1

From the library of: Diamond Needle Corp

No.	Part No.	Part name	品 名	V,W	EMK
21	84-7110-0	Screw	ネ ジ	2	2
22	71-7870-0	Main shaft	前下シャフト		1
23	75-2450-0	Feed crank link collar	カラー	1	1
24	91-2670-0	Bearing	ベアリング	1	1
25	75-1640-0	Washer	ワッシャ	1	1
26	86-4120-0	Nut	ナット	1	1
27	67-3140-0	Feed rocker arm	送り連結レバー	1	1
28	84-3660-0	Screw	ネ ジ	2	2
29	63-3570-0	Feed rocker link	送りダルマC	1	1
30	84-8140-0	Screw	ネ ジ	1	1
31	71-4130-0	Feed rocker link Pin	ダルマピン	1	1
32	93-2610-0	Snap link	止 輪	1	1
33	75-3720-0	Washer	ワッシャ	2	2
34	51-1020-0	Differential feed rocker	2枚送り元台B	1	1
35	84-5210-0	Screw	ネ ジ	2	2
36	51-1050-0	Feed rocker segment shot plate	2枚送り調節板	1	1
37	84-3630-0	Screw	ネ ジ	3	3
38	71-5310-0	Shaft	後送歯取付シャフト	1	1
39	84-5760-0	Screw	ネ ジ	1	1
40	71-6470-0	Feed rocker arm shaft	2枚送元台シャフト	1	1
41	75-1320-1	Collar	カラー	1	1
42	84-8160-0	Screw	ネ ジ	1	1
43	18-7190-0	Needle guard G	針受けG	1	
44	84-1610-0	Screw	ネ ジ	2	
45	51-1030-0	Main differential feed	2枚送土台A	1	1
46	84-5210-0	Screw	ネ ジ	1	1
47	51-1090-0	Differential feed bar guide	前送り台抱き	1	1
48	84-3790-0	Screw	ネ ジ	1	1
49	66-5060-0	Feed crank link	連結クランク	1	1
50	86-3110-0	Nut	ナット	1	1
51	75-4670-0	Washer	ワッシャ	1	1
52	51-1130-0	Crank set pin	クランク取付ピン	1	1
54	75-4580-0	Washer	ワッシャ	1	1
55	86-4110-0	Nut	ナット	1	1
56	51-1200-0	Front feed dog holder bracket	前送歯取付台B	1	1
57	84-3630-0	Screw	ネ ジ	1	1
58	51-1110-0	Differential feed bar guide	前送台抱きガイド	2	2
59	84-1640-0	Screw	ネ ジ	4	4
60	84-4640-0	Screw	ネ ジ	1	1
61	84-3660-0	Screw	ネ ジ	1	1
62	84-1620-0	Screw	ネ ジ	2	2
63	18-7090-0	Needle guard holder	針受け取付金具B	1	
64	18-7200-0	Needle guard holder B	針受け取付板B	1	
65	81-1410-0	Bushing	ブッシュ	2	2
66	84-6140-0	Screw	ネ ジ	1	
67	75-4550-0	Washer	ワッシャ	1	
68	18-7050-0	Needle guard	針受け		1
69	84-5710-0	Screw	ネ ジ		2
70	84-3140-0	Screw	ネ ジ	1	1
71	23-3910-0	Felt	フェルト	1	1
72	23-3410-0	Felt	フェルト	1	1
73	84-6120-0	Screw	ネ ジ	1	1
74	84-7610-0	Screw	ネ ジ	1	1
75	67-1320-1	Looper avoid lever	針返シダルマレバー	1	1
76	60-7240-0	Feed rocker arm set	送り連結レバーベアリングセット	1	1
77	87-1360-0	Screw	ネ ジ	1	1
78	88-1360-0	Nut	ナット	1	1
79	23-3910-0	Felt	フェルト	1	1

# 9. Looper (ルーパー台機構)

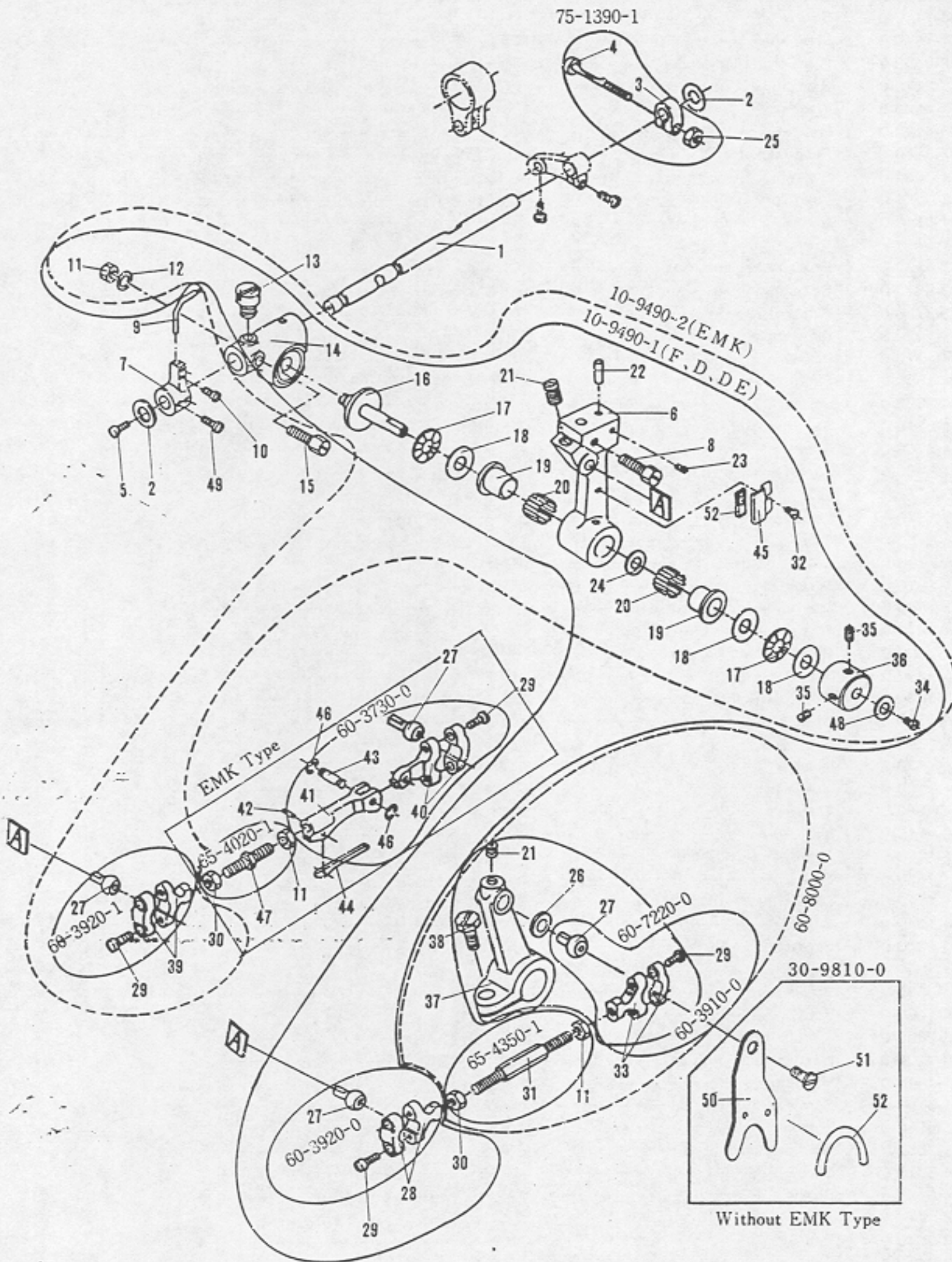

From the library of: Diamond Needle Corp

No.	Part No.	Part name	品名	V.W	EMK
1	71-5610-0	Looper holder shaft	ルーバー台シャフト	1	1
2	75-3720-0	Washer	ワッシャ	2	2
3	75-1390-1	Looper holder shaft collar	ルーバー台シャフト締めカラー	1	1
4	71-4540-0	Pin	締めカラー止ピン	1	1
5	84-7610-0	Screw	ネジ	1	1
6	19-3490-0	Looper holder	ルーバー台	1	1
7	18-7220-0	Needle bar guide bracket	針ガイドブラケットB	1	1
8	84-6160-0	Screw	ネジ	3	3
9	18-7250-0	Needle bar guide	針ガイドC	1	1
10	84-1620-0	Screw	ネジ	2	2
11	86-4110-0	Nut	ナット	2	2
12	75-4580-0	Washer	ワッシャ	1	1
13	84-7180-0	Screw	ネジ	1	1
14	19-3090-0	Looper rocker	ルーバー元台	1	1
15	84-7670-0	Screw	ネジ	1	1
16	71-8110-0	Shaft	ルーバー台軸受けシャフト	1	1
17	92-2300-0	Thrust bearing	スラストベアリング	2	2
18	75-4490-0	Washer	スラストワッシャ	3	3
19	81-8100-0	Bushing	ルーバー台ブッシュ	2	2
20	91-1060-0	Needle roller	ニードルローラー	32	32
21	84-7180-0	Screw	ネジ	1	1
22	71-2160-0	Pin	ピン	1	1
23	84-1120-0	Screw	ネジ	1	1
24	75-3700-0	Washer	スペースワッシャ	1	1
25	86-3140-0	Nut	ナット	1	1
26	75-4010-0	Washer	上飾りロッドワッシャ	1	1
27	61-5130-U	Connecting ball	ルーバー振元ロッド玉C	2	2
28	63-8120-1	Connecting rod (left)	連結ロッド(左)	1	
29	84-5670-0	Screw	ネジ	4	4
30	86-4120-0	Nut (left)	ナット(左)	1	1
31	65-4350-0	Connecting bar	連結棒	1	
32	84-1150-0	Screw	ネジ	1	1
33	63-8110-1	Connecting rod	連結ロッド	1	1
34	84-4010-0	Screw	ネジ	1	1
35	84-5210-0	Screw	ネジ	2	2
36	75-8110-0	Collar	スラストカラー	1	1
37	67-2290-1	Looper driving lever	ルーバー振元レバー	1	1
38	85-2100-0	Screw	ネジ	1	1
39	63-8130-1	Connecting rod (left)	連結ロッド(左)		1
40	63-8210-U	Connecting rod	ルーバー折り曲げロッド		1
41	65-9020-0	Looper driving connecting link	ルーバー折り曲げダルマ金具		1
42	71-2010-0	Pin	ピン		1
43	71-3220-0	Pin	折り曲げダルマピン		1
44	79-6010-0	Plate spring	板バネ		1
45	23-8100-0	Presser bracket	フェルト押え金具	1	1
46	93-2010-0	Stop ring	ストップリング		2
47	65-4020-0	Connecting bar	連結棒		1
48	75-4600-0	Washer	ワッシャ	1	1
49	84-8160-0	Screw	ネジ	1	1
50	39-8100-0	Oil fence	振元レバーオイルフェンス	1	
51	84-1610-0	Screw	ネジ	1	
52	23-3410-0	Felt	フェルト	1	



# 10. Foot letter Components (押え揚げ機構)

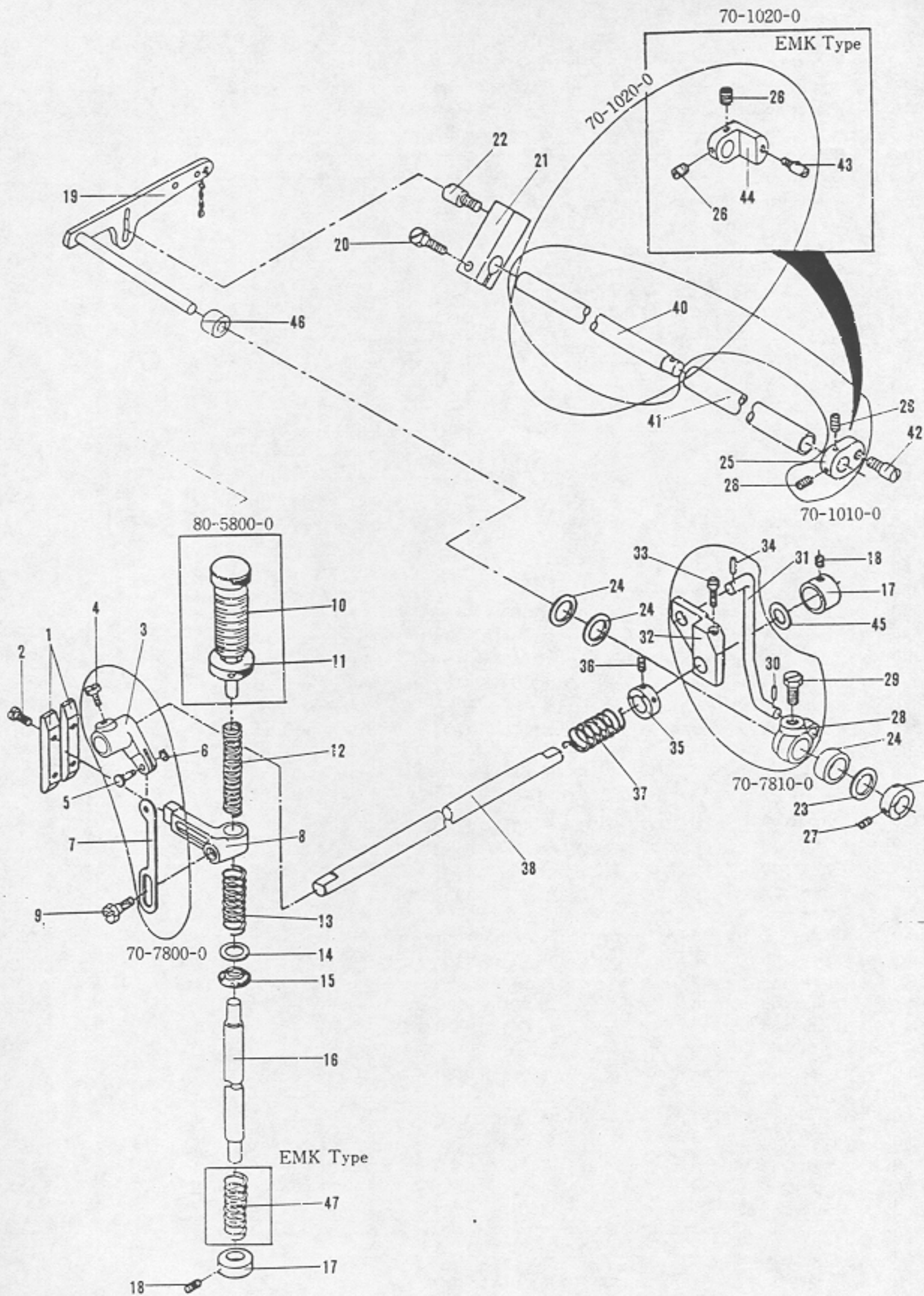

From the library of: Diamond Needle Corp

No.	Part No.	Part name	品 名	V.W	EMK
1	77-1390-0	Presser bar connecting guide D	押棒案内板D	2	2
2	84-5670-0	Screw	ネ ジ	4	4
3	77-8020-0	Foot lifter crank	押揚げクランク	1	1
4	84-8160-0	Screw	ネ ジ	1	1
5	71-3260-0	Pin	押揚げ連結ピン	1	1
6	93-2000-0	E-ring	E-リング	1	1
7	77-8010-0	Foot lifter connecting plate	押揚げ連結板	1	1
8	77-8030-1	Presser bar guide	押棒抱き	1	1
9	84-8170-0	Screw	ネ ジ	1	1
10	85-8010-0	Screw	ネ ジ	1	1
11	86-8510-0	Nut	ナット	1	1
12	79-1230-0	Presser bar spring	上輪押えバネ	1	1
13	79-0420-0	Oil seal spring	バネ	1	1
14	75-4360-0	Washer	ワッシャ	1	1
15	23-3110-0	Oil seai	押棒油止めシール	1	1
16	71-5430-0	Presser bar C	押棒C	1	1
17	75-1540-1	Coilar	カラー	2	1
18	84-5110-0	Screw	ネ ジ	2	2
19	77-8880-0	Control iever	押揚げコントロールレバーB	1	1
20	84-8120-0	Screw	ネ ジ	1	1
21	77-1030-0	Adjusting post supporter	調子芯棒止め板	1	1
22	84-5610-0	Screw	ネ ジ	1	1
23	75-3720-0	Washer	ワッシャ	2	2
24	94-8020-0	Oil seai	オイルシール	2	2
25	77-1010-0	Lifter lever connecting	丸 駒	1	
26	84-5210-0	Screw	ネ ジ	2	2
27	84-6160-0	Screw	ネ ジ	1	1
28	77-8060-1	Lever A	押揚げ連結レバーA	1	1
29	85-2120-0	Screw	ネ ジ	1	1
30	93-6110-0	Pin	スナップピンA	1	1
31	77-8080-0	Connecting rod	押揚げ連結棒	1	1
32	77-8070-1	Lever B	押揚げ連結レバーB	1	1
33	84-7180-0	Screw	ネ ジ	1	1
34	93-6110-0	Pin	ピ ン	1	1
35	77-8150-0	Spring set collar	カラー	1	1
36	85-1130-0	Screw	ネ ジ	2	2
37	79-2270-0	Spring	バネ	1	1
38	71-5550-0	Foot lifter interlocking shaft	押揚げ連動シャフト	1	1
39	75-1300-1	Collar	カラー	1	1
40	77-1110-0	Crank shaft B	押揚げクランクシャフトB	1	1
41	77-1210-0	Crank shaft pipe	押揚げクランクシャフトパイプ	1	1
42	84-5620-0	Screw	ネ ジ	1	
43	84-5730-0	Screw	ネ ジ		1
44	77-1020-0	Lifter lever connecting (EMK)	EMK丸駒		1
45	75-4510-0	Washer	ワッシャ	1	1
46	75-8880-0	Collar	押揚げスペースカラー	1	1
47	79-1420-0	Spring	バネ		1

From the library of: Diamond Needle Corp

# 11. Spreader components (上飾り機構) W8100

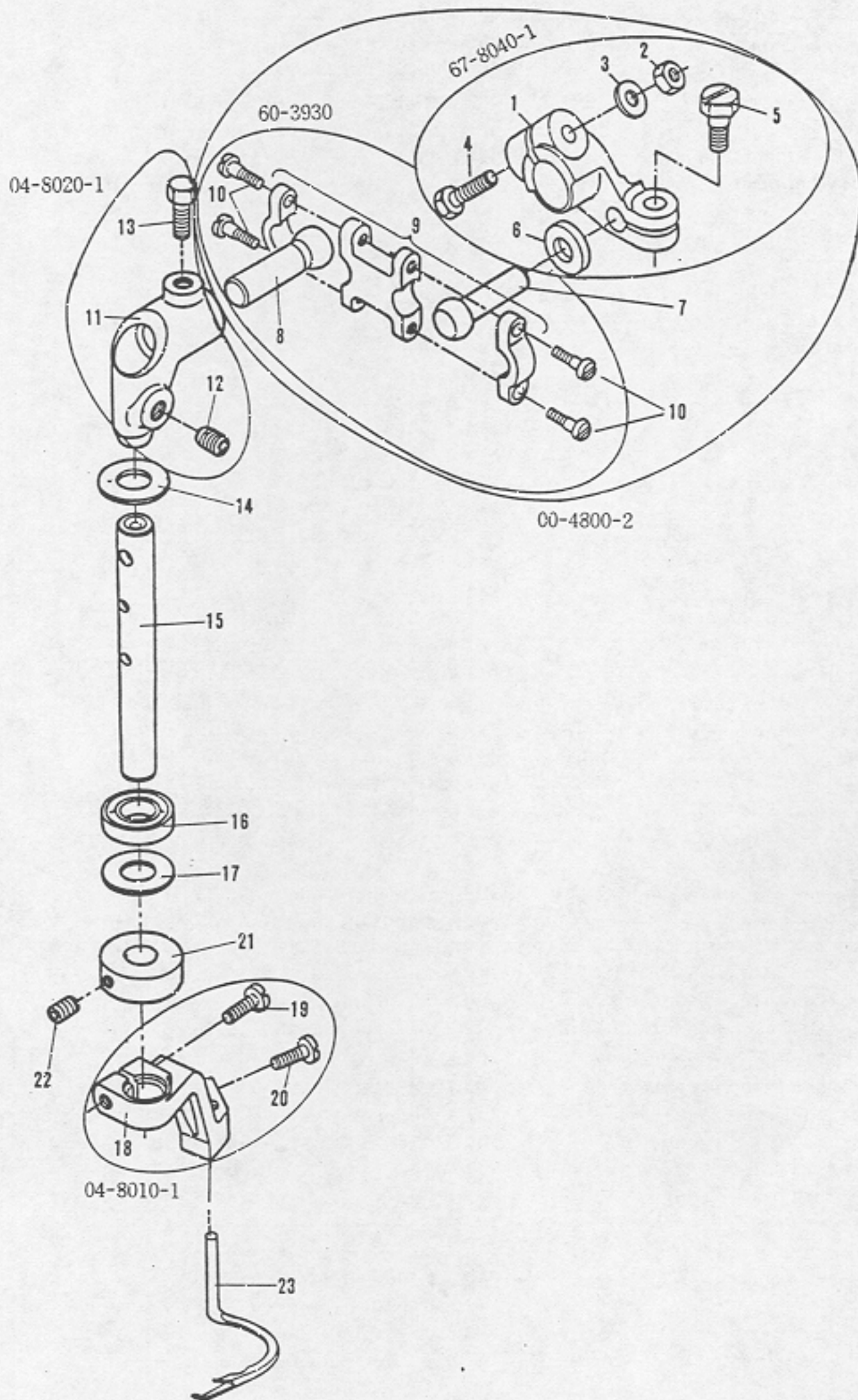

From the library of: Diamond Needle Corp

No.	Part No.	Part name	品 名	Q, ty
1	67-8040-0	Coverring lever .....	上飾り駆動レバー.....	1
2	86-5010-0	Nut .....	ナット .....	1
3	75-5520-0	Washer .....	ワッシャ .....	1
4	71-4550-0	Screw Pin.....	立ロット連結レバー止メピン.....	1
5	84-4130-0	Screw .....	ネジ.....	1
6	75-3980-0	Washer .....	ワッシャ.....	1
7	61-8020-U	Connecting rod B .....	上飾り連結ロッド玉B .....	1
8	61-8010-U	Connecting rod A .....	上飾り連結ロッド玉A .....	1
9	63-5250-1	Connecting ball joint .....	上飾り連結ロッド.....	1
10	84-1720-0	Screw .....	ネジ.....	4
11	04-8020-0	Joint .....	上飾りジョイント.....	1
12	84-7260-0	Screw .....	ネジ.....	1
13	84-6110-0	Screw .....	ネジ.....	1
14	75-3560-0	Washer .....	ワッシャ .....	1
15	71-5530-0	Shaft .....	飾り土台シャフト.....	1
16	94-8010-0	Oil seal .....	オイルシール.....	1
17	75-1800-0	Washer .....	ワッシャ.....	1
18	04-8010-1	Looper crank .....	上飾りルーパークランプ.....	1
19	84-5670-0	Screw .....	ネジ.....	1
20	84-3630-0	Screw .....	ネジ.....	1
21	75-1520-1	Coolar .....	カラー.....	1
22	84-5110-0	Screw .....	ネジ.....	2
23	19-8070-0	Coverring looper .....	上飾りルーパーB .....	1

From the library of: Diamond Needle Corp

# 12. Attachments (アタッチメント)

W8100DE Type  
V7100DE Type

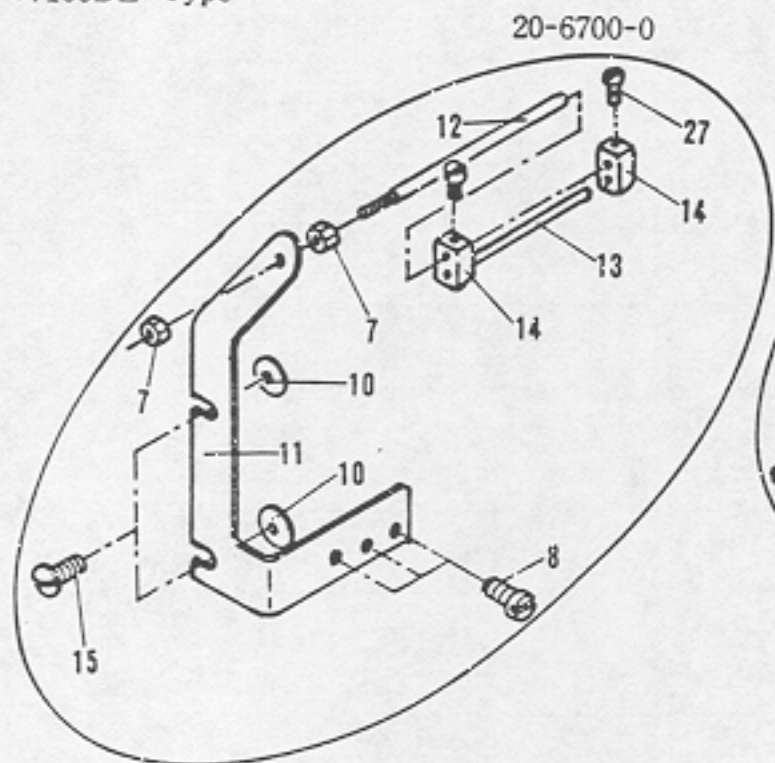

Tape guide

20-6020-0

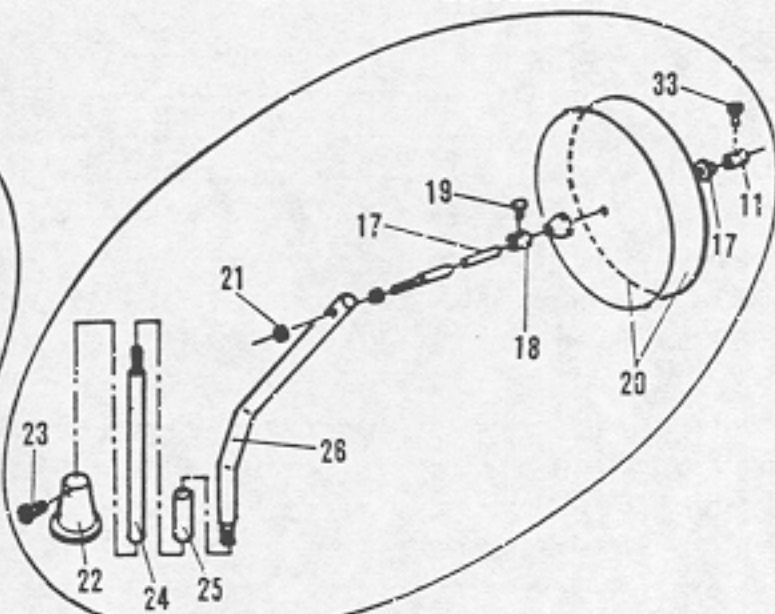

ES-2

W8100F Type  
V7100F Type

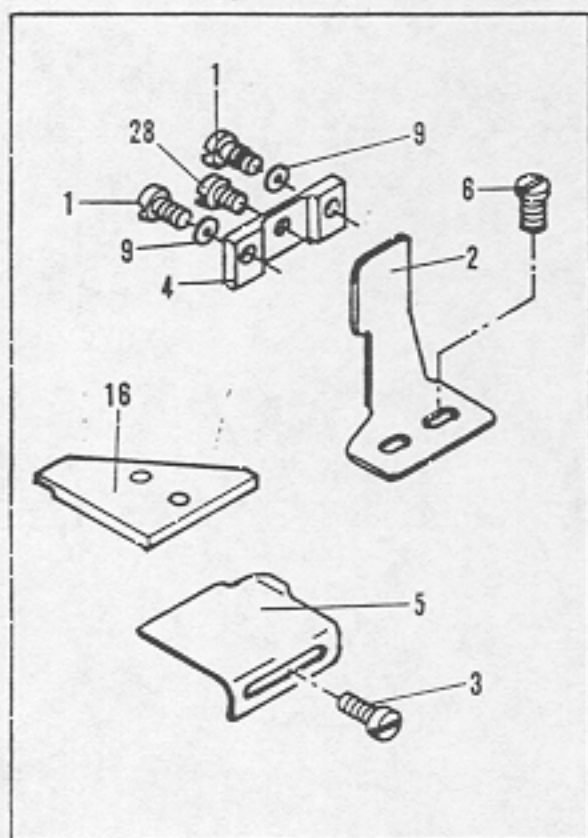

20-6140-0

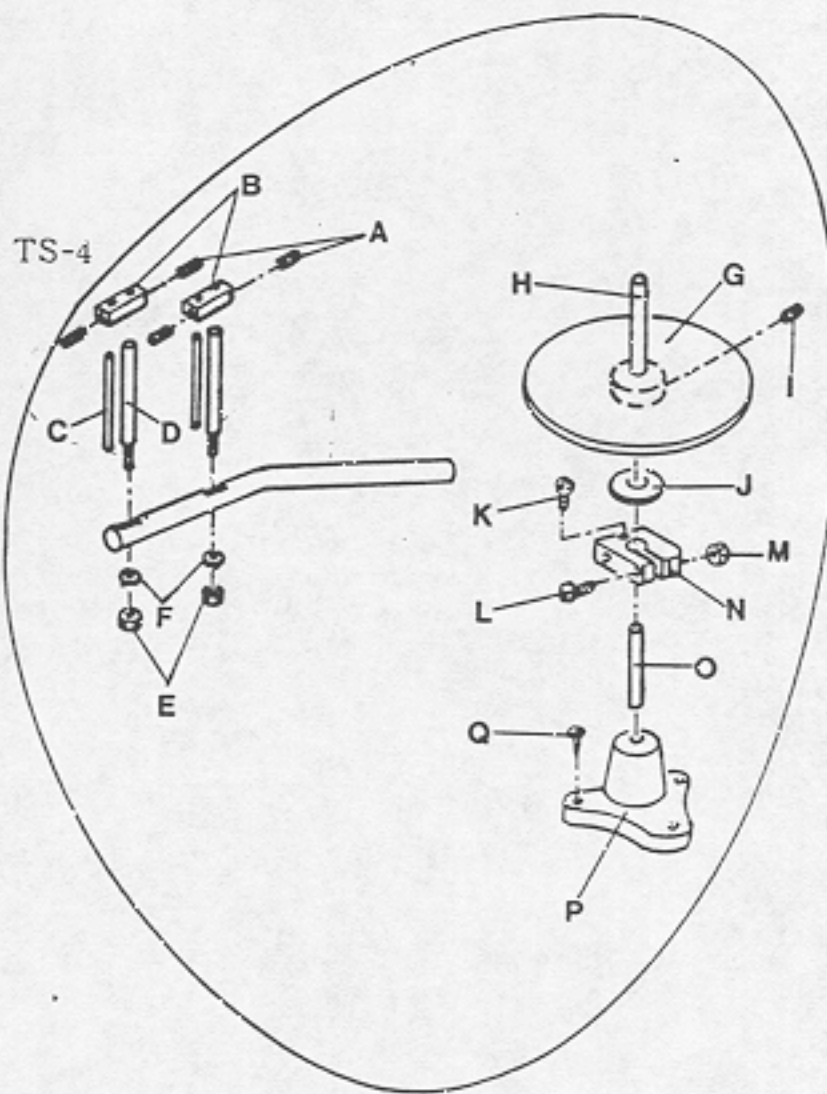

From the library of: Diamond Needle Corp

No.	Part No.	Part name	品 名	F	D.DE
1	84-5720-0	Screw	ネ ジ	5	
2	26-7250-0	Folder base	ラッパ取付台	1	
3	84-1620-0	Screw	ネ ジ	1	
4	26-7240-0	Folder base For F	ラッパ抱き	1	
5	26-7610-0	Plate	定規 (前)	1	
6	85-1820-0	Screw	ネ ジ	2	
7	86-4110-0	Nut	ナット		2
8	84-3630-0	Screw	ネ ジ		3
9	75-4550-0	Washer	ワッシャ	2	
10	75-4560-0	Washer	ワッシャ		2
11	26-7060-0	Rubber puller guide plate	ゴムプーラー案内板		1
12	26-7510-0	Rubber puller guide bar	ゴムプーラー取付棒		1
13	26-7520-0	Rubber puller guide bar	ゴムプーラー案内棒		1
14	26-7530-0	Rubber puller fittings	ゴムプーラー取付全具		2
15	84-3700-0	Screw	ネ ジ		2
16	21-1910-0	Ruler plate F	定規板	1	
17	26-8660-0	Tape reel post	テープ支柱 C		1
18	26-8690-0	Stop collar	円板受け止めカラー B		2
19	87-1560-0	Hex. bolt	メートルネジ		2
20	26-8670-0	Tape reel disk	φ226 円板テープガイド		2
21	88-1760-0	Nut	ナット		2
22	26-8760-0	Base	テープ立元台 B		1
23	87-1610-0	Hex. bolt	メートルネジ		2
24	26-8770-0	Post A	支柱パイプ A		2
25	26-8790-0	Connecting pipe	支柱パイプ継手		1
26	26-8780-0	Post B	支柱パイプ B		1
27	84-1120-0	Screw	ネ ジ		2
28	84-5710-0	Screw	ネ ジ		1

From the library of: Diamond Needle Corp

# 13. Front trimmer mechanism (前メス機構) EMK

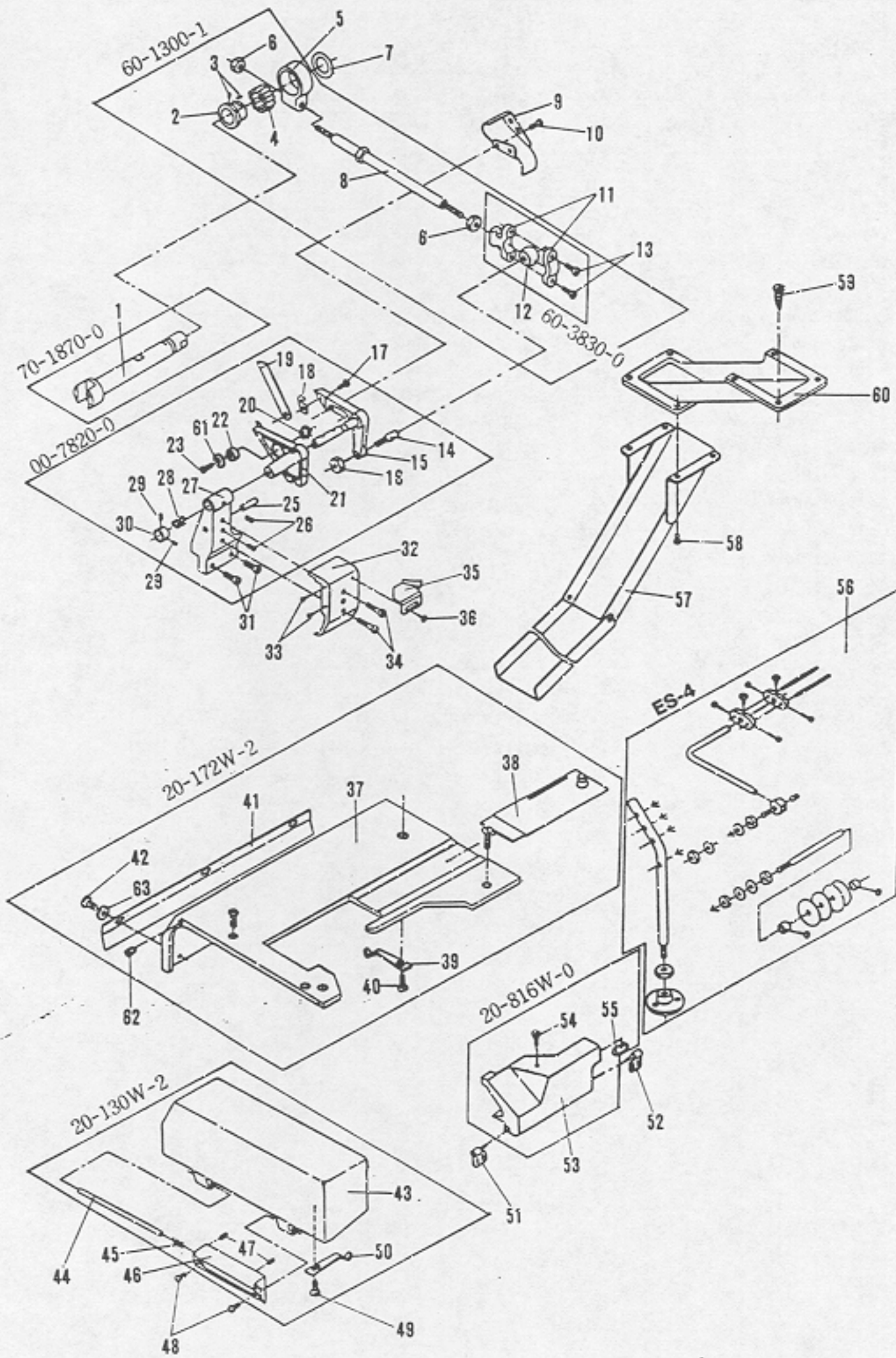

From the library of: Diamond Needle Corp

No.	Part No.	Part name	品 名	Q, ty
1	71-7870-0	Main shaft 8G	前下シャフト8G	1
2	61-2550-U	Front knife eccentric	前メスエキセン玉	1
3	84-7150-0	Screw	ネ ジ	2
4	91-4110-0	Front trimmer bearing	前メスベアリング	1
5	63-2110-U	Front trimmer connecting link	前メス連結ダルマ	1
6	86-4110-0	Nut	ナット	2
7	75-3210-0	Washer for front scalpel bearing	前メスベアリングワッシャ	1
8	65-5070-1	Front knife connecting bar set	前メス連結棒	1
9	07-1490-0	EMK chute	切屑落とし	1
10	84-3640-0	Screw	ネ ジ	2
11	63-8110-1	Looper connecting link-right	連結ロッド右	1
12	61-8410-U	Front trimmer connecting ball joint	前メスジョイントボール	1
13	84-5670-0	Screw	ネ ジ	2
14	71-1650-0	Pin	メス駆動連結ピン	1
15	07-1670-1	Upper knife bracket	上メスブラケット	1
16	86-4130-0	Nut	ナット	1
17	84-3620-0	Screw	ネ ジ	1
18	07-1700-0	Upper knife	上メス	1
19	07-1690-0	Lower knife	下メス	1
20	07-1660-0	Clamp	下メス取付金具	1
21	07-1820-2	EMK lower knife bracket	EMKメスブラケット	1
22	07-1470-0	Fixing washer for EMK lower knife	下メス取付座金	1
23	84-7630-0	Screw	ネ ジ	1
25	71-2590-0	Pin	偏心ピン	1
26	84-5210-0	Screw	ネ ジ	2
27	07-183G-0	Base	前ベースブラケット	1
28	79-1420-0	Spring	前メス上メスバネ	1
29	84-5110-0	Screw	ネ ジ	2
30	75-1520-1	Shaft collar	シャフトカラー	1
31	84-7630-0	Screw	ネ ジ	2
32	07-815W-2	Front cover (left)	メスカバーセット左	1
33	25-8010-0	Cushion	二枚カバー防振ゴム	2
34	84-5660-0	Screw	ネ ジ	2
35	26-7620-0	Front ruler	EMK定規	1
36	84-3700-0	Screw	ネ ジ	1
37	21-723W-0	Upper cloth plate	上ベースカバー	1
38	21-5210-0	Slide plate	差し板A	1
39	79-5010-0	Spring	定規板板バネ	1
40	84-3610-0	Screw	ネ ジ	1
41	21-443W-0	Support cover	上ベース補助カバー	1
42	84-5740-0	Screw	ネジ	3
43	21-350W-0	Slide cover	横ベースカバー	1
44	71-3080-0	Hinge pin	ヒンジピン	1
45	79-2330-0	Spring	取付巻バネ	1
46	25-108W-0	Hinge	ヒンジ大	1
47	84-3140-0	Screw	ネ ジ	2
48	84-5660-0	Screw	ネ ジ	2
49	84-5710-0	Screw	ネ ジ	1
50	79-5020-0	Spring	横ベースカバー板バネ	1
51	25-1010-0	Cover hinge right	カバーヒンジ右	1
52	25-1020-0	Cover hinge left	カバーヒンジ左	1
53	21-816W-0	Front cover right	前メスカバー右	1
54	84-4620-0	Screw	ネ ジ	1
55	71-4010-0	Pin	定規台裏バネピン	1
56	20-6040-0	Tape stand	ES-4テープ立テ	1
57	28-7010-0	Chip chute B	前メスダストシュート	1
58	84-5770-0	Screw	ネ ジ	4
59	87-9010-0	Screw	ネ ジ	4
60	07-001G-0	Chip chute A	ダスターシュートA	1
61	75-4460-0	Washer	ワッシャ	1
62	25-8010-0	Cushion	防振ゴム	2
63	75-4680-0	Washer	ワッシャ	3

From the library of: Diamond Needle Corp



# 14. Front puller mechanism (前プーラー装置) EMK

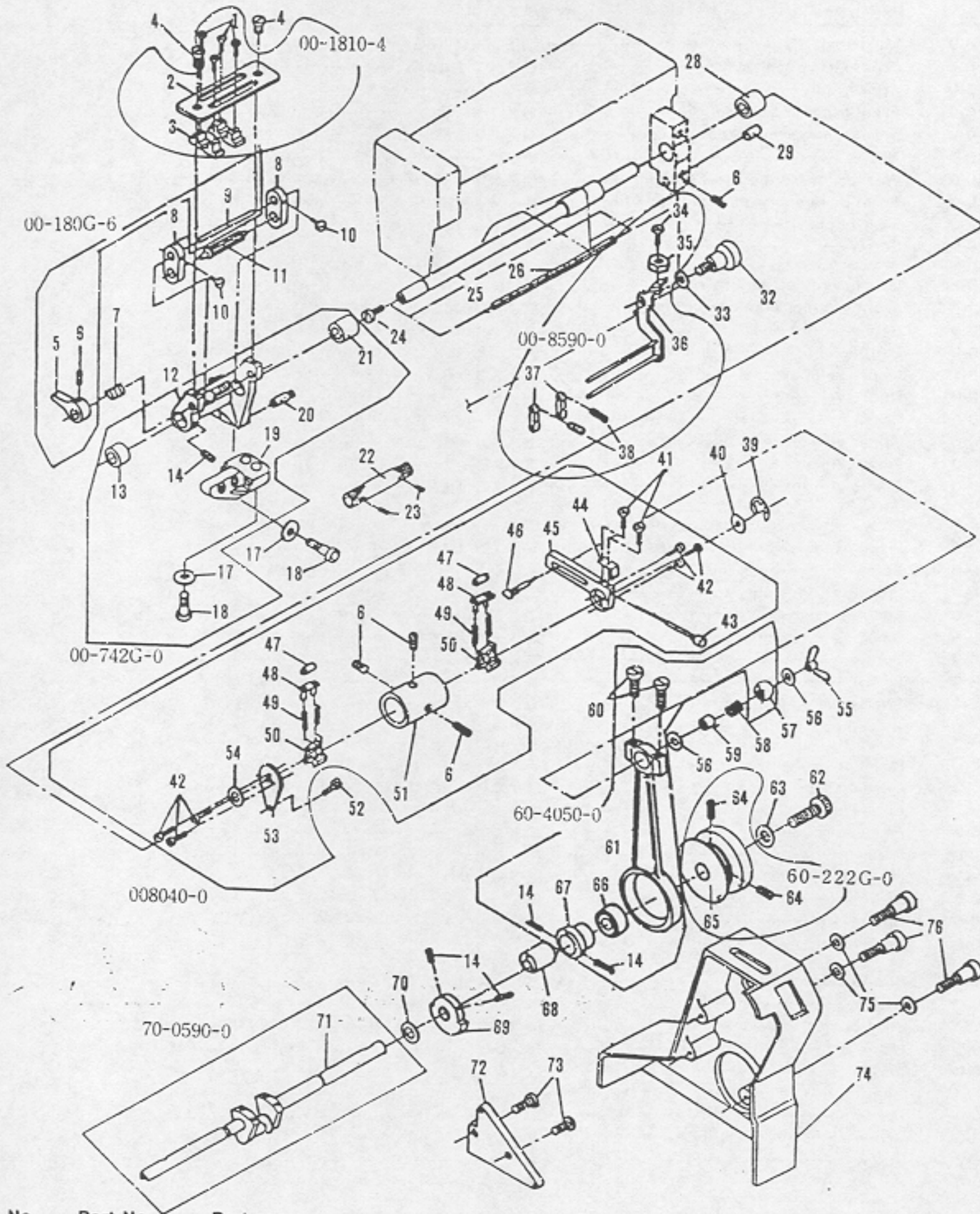

From the library of: Diamond Needle Corp

No.	Part No.	Part name	品名	Q. ty
1	84-3610-0	Screw	ネジ	4
2	01-7140-0	EMK elastic guide plate	ゴムガイドプレート	1
3	01-8370-0	Rubber slide guide	ゴムスライドガイド	4
4	84-5740-0	Screw	ネジ	2
5	01-206G-0	Elastic adjusting lever	ゴム調節レバー	1
6	84-7180-0	Screw	ネジ	5
7	79-1580-0	Adjusting spring	ゴム調節巻バネ	1
8	01-8050-0	Bracket	ゴム調節ローラーアーム	2
9	71-5050-0	EMK small roller arm shaft	小ローラーアームシャフト	1
10	84-1640-0	Screw	ネジ	2



No.	Part No.	Part name	品 名	Q, ty
11	01-7120-0	EMK small feed roller	ゴム調節小ローラー	1
12	01-860G-0	EMK front puller base	前プーラーベース	1
13	81-3290-0	Bushing	ゴム調節ローラーブッシュ	1
14	84-5210-0	Screw	ネジ	5
17	75-5270-0	Washer	ワッシャ	4
18	87-1710-0	Screw	ネジ	4
19	01-861G-0	Rear puller mount	後プーラー取付台	1
20	01-7320-0	Elastic guide spring pin	ゴムガイドスプリングピン	1
21	81-3280-0	Bushing	ゴム調節ローラーブッシュ (右)	1
22	01-8570-0	Metering roller	送りローラー	1
23	84-3140-0	Screw	ネジ	2
24	84-7610-0	Screw	ネジ	1
25	71-8010-0	Drive shaft	プーラードライブシャフト	1
26	23-3410-0	Felt	フェルト	1
28	81-8120-0	Bushing	プーラードライブシャフトブッシュ	1
29	71-8020-0	Pin	回り止めピン	1
32	84-5880-0	Screw	ネジ	1
33	02-1180-0	M5 wave washer	波座金WW5	1
34	87-1430-0	Screw	ネジ	1
35	88-1360-0	Nut	ナット	1
36	01-8590-0	Elastic guide bar holder	ゴムガイドブラケット	1
37	01-8580-0	Elastic guide	ゴムガイド	2
38	84-1010-0	Screw	ネジ	2
39	93-2210-0	Stop ring	ストップリング	1
40	75-4000-0	Washer	ワッシャ	1
41	84-1610-0	Screw	ネジ	2
42	84-1620-0	Screw	ネジ	6
43	01-8540-0	Screw	プーラー調節ネジ	1
44	02-4030-0	Stopper	プーラー調節ネジストッパー	1
45	67-8110-0	Lever	前プーラードライブレバー	1
46	01-8520-0	Pin	支持ピン	1
47	71-4660-0	Puller clutch roller	プーラーバローラー	6
48	02-0490-0	Roller pin plate	ローラーピン当り板	6
49	79-0440-0	Check clutch spring	前プーラーババネ	12
50	02-1010-0	Clutch A	バ	2
51	01-0450-0	Clutch housing	バハウジング	1
52	84-5640-0	Screw	ネジ	1
53	01-8510-0	Front puller drive lever	前プーラー駆動レバー	1
54	01-8560-0	Spring	皿バネ	1
55	01-8530-0	Nut	蝶ナット	1
56	75-4070-0	Puller driving ball washer	プーラー連結玉ワッシャ	2
57	61-4030-0	Puller driving ball	プーラー連結玉	1
58	91-2660-0	Needle bearing	ニードルベアリング	1
59	75-4090-0	Cooler	軸受内輪	1
60	84-5680-0	Screw	ネジ	2
61	63-2060-0	Puller crank rod	プーラークランクロッド	1
62	84-2630-0	Screw	ネジ	1
63	75-1830-0	Pully thrust washer	プーリースラストワッシャ	1
64	85-1140-0	Screw	ネジ	2
65	69-222G-0	Pulley	プーリー	1
66	91-9010-0	Needle bearing	ボールベアリング	1
67	61-2610-0	Connecting ball outer	エキセン玉外側	1
68	61-2600-0	Connecting ball inner	エキセン玉内側	1
69	69-2130-0	Bearing thrust washer	エキセン調節ホイール	1
70	75-8140-0	Bearing thrust washer	ベアリングスラストワッシャ	1
71	71-8890-0	Crank shaft	クランクシャフト	1
72	01-8550-0	Pulley cover mount plate	プーリーカバー取付ライナー	1
73	84-5660-0	Screw	ネジ	4
74	21-317G-0	Pulley cover	プーリーカバー	1
75	75-4530-0	Washer small	ワッシャ (小)	3
76	87-1890-0	Screw	ネジ	3

From the library of: Diamond Needle Corp





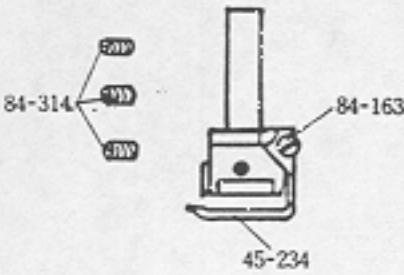
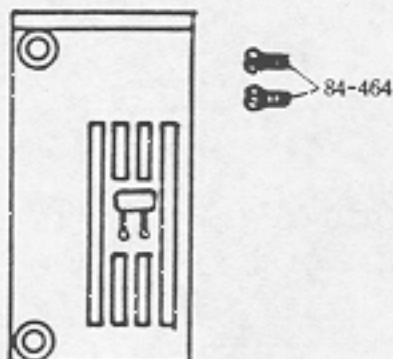
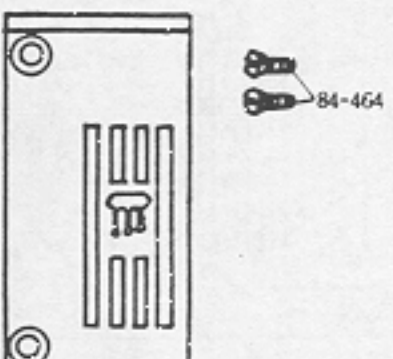
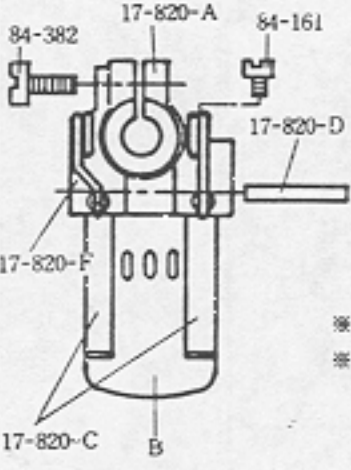
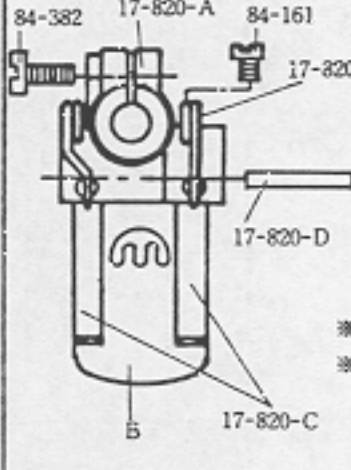
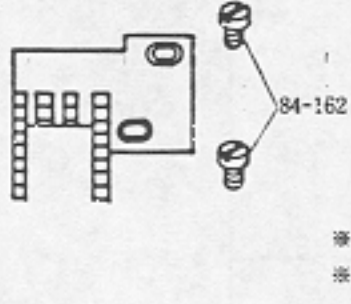
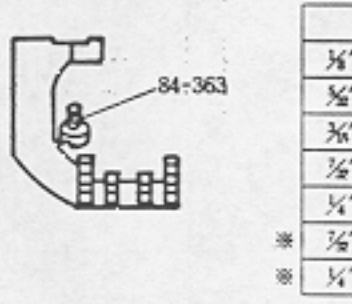

# 15. Gauge (ゲージ)

No.	Model		Feed dog holder	Needle holder	Needle plate	Feed dog (front)	Feed dog (rear)	Presser foot	Looper
1	W8102D	1/8	51-1180-0	12-8110-1	14-7240-0	15-7240-0	15-7550-0	17-8240-1	19-8010-0
2		5/32	51-1180-0	12-8120-1	14-7340-0	15-7240-0	15-7550-0	17-8340-1	19-8010-0
3		3/16	51-1180-0	12-8130-1	14-7440-0	15-7230-0	15-7530-0	17-8440-1	19-8010-0
4		7/32	51-1180-0	12-8140-1	14-7540-0	15-7230-0	15-7530-0	17-8540-1	19-8010-0
5		1/4	51-1180-0	12-8150-1	14-7640-0	15-7230-0	15-7530-0	17-8640-1	19-8010-0
6	W8103D	7/32	51-1180-0	12-8010-1	14-8540-0	15-7230-0	15-7530-0	17-8840-1	19-8010-0
7		1/4	51-1180-0	12-8020-1	14-8640-0	15-7230-0	15-7530-0	17-8940-1	19-8010-0
8	V7101D		51-1180-0	12-8010-1	14-7040-0	15-7240-0	15-7540-0	17-7040-1	19-8010-0
9	V7102D	1/8	51-1180-0	12-8110-1	14-7240-0	15-7240-0	15-7550-0	17-7240-1	19-8010-0
10		5/32	51-1180-0	12-8120-1	14-7340-0	15-7240-0	15-7550-0	17-7340-1	19-8010-0
11		3/16	51-1180-0	12-8130-1	14-7440-0	15-7230-0	15-7530-0	17-7440-1	19-8010-0
12		7/32	51-1180-0	12-8140-1	14-7540-0	15-7230-0	15-7530-0	17-7540-1	19-8010-0
13		1/4	51-1180-0	12-8150-1	14-7640-0	15-7230-0	15-7530-0	17-7640-1	19-8010-0
14	V7103D	7/32	51-1180-0	12-8010-1	14-8540-0	15-7230-0	15-7530-0	17-7840-1	19-8010-0
15		1/4	51-1180-0	12-8020-1	14-8640-0	15-7230-0	15-7530-0	17-7940-1	19-8010-0
16	W8102C	3/16	51-1180-0	12-8130-1	14-8030-0	15-7310-0	15-7610-0	17-8470-1	19-8010-0
17		7/32	51-1180-0	12-8140-1	14-8040-0	15-7310-0	15-7610-0	17-8570-1	19-8010-0
18		1/4	51-1180-0	12-8150-1	14-8050-0	15-7310-0	15-7610-0	17-8670-1	19-8010-0
19	W8103C	7/32	51-1180-0	12-8010-1	14-8010-0	15-7310-0	15-7610-0	17-8870-1	19-8010-0
20		1/4	51-1180-0	12-8020-1	14-8020-0	15-7310-0	15-7610-0	17-8970-1	19-8010-0
21	V7101F		51-1170-0	12-8010-1	14-7030-0	15-7260-0	15-7570-0	17-7030-1	19-8010-0
22	V7102,W8102F	1/8	51-1170-0	12-8110-1	14-7260-0	15-7290-0	15-7560-0	17-8260-1	19-8010-0
23		5/32	51-1170-0	12-8120-1	14-7360-0	15-7290-0	15-7560-0	17-8360-1	19-8010-0
24		3/16	51-1170-0	12-8130-1	14-7460-0	15-7270-0	15-7560-0	17-8460-1	19-8010-0
25		7/32	51-1170-0	12-8140-1	14-7560-0	15-7270-0	15-7560-0	17-8560-1	19-8010-0
26		1/4	51-1170-0	12-8150-1	14-7660-0	15-7270-0	15-7560-0	17-8660-1	19-8010-0
27	V7103,W8103F	7/32	51-1170-0	12-8010-1	14-8560-0	15-7270-0	15-7560-0	17-8860-1	19-8010-0
28		1/4	51-1170-0	12-8020-1	14-8660-0	15-7270-0	15-7560-0	17-8960-1	19-8010-0
29	V7102DE	1/8	51-1180-0	12-8110-1	14-7250-0	15-7240-0	15-7550-0	17-7250-1	19-8010-0
30		5/32	51-1180-0	12-8120-1	14-7350-0	15-7240-0	15-7550-0	17-7350-1	19-8010-0
31		3/16	51-1180-0	12-8130-1	14-7450-0	15-7230-0	15-7530-0	17-7450-1	19-8010-0
32		7/32	51-1180-0	12-8140-1	14-7550-0	15-7230-0	15-7530-0	17-7550-1	19-8010-0
33		1/4	51-1180-0	12-8150-1	14-7650-0	15-7230-0	15-7530-0	17-7650-1	19-8010-0
34	V7103DE	7/32	51-1180-0	12-8010-1	14-8550-0	15-7230-0	15-7530-0	17-7850-1	19-8010-0
35		1/4	51-1180-0	12-8020-1	14-8650-0	15-7230-0	15-7530-0	17-7950-1	19-8010-0
36	W8102DE	1/8	51-1180-0	12-8110-1	14-7250-0	15-7240-0	15-7550-0	17-8250-1	19-8010-0
37		5/32	51-1180-0	12-8120-1	14-7350-0	15-7240-0	15-7550-0	17-8350-1	19-8010-0
38		3/16	51-1180-0	12-8130-1	14-7450-0	15-7230-0	15-7530-0	17-8450-1	19-8010-0
39		7/32	51-1180-0	12-8140-1	14-7550-0	15-7230-0	15-7530-0	17-8550-1	19-8010-0
40		1/4	51-1180-0	12-8150-1	14-7650-0	15-7230-0	15-7530-0	17-8650-1	19-8010-0
41	W8103DE	7/32	51-1180-0	12-8010-1	14-8550-0	15-7230-0	15-7530-0	17-8850-1	19-8010-0
42		1/4	51-1180-0	12-8020-1	14-8650-0	15-7230-0	15-7530-0	17-8950-1	19-8010-0
43	V7102,W8102EMK	1/8	51-1170-0	12-8110-1	14-7280-0	15-7280-0	15-8280-0	17-8290-1	19-8010-0
44		5/32	51-1170-0	12-8120-1	14-7380-0	15-7280-0	15-8280-0	17-8390-1	19-8010-0
45		3/16	51-1170-0	12-8130-1	14-7480-0	15-7280-0	15-8280-0	17-8490-1	19-8010-0
46		7/32	51-1170-0	12-8140-1	14-7580-0	15-7280-0	15-8280-0	17-8590-1	19-8010-0
47		1/4	51-1170-0	12-8150-1	14-7680-0	15-7280-0	15-8280-0	17-8690-1	19-8010-0
48	V7103,W8103EMK	7/32	51-1170-0	12-8010-1	14-8580-0	15-7280-0	15-8280-0	17-8890-1	19-8010-0
49		1/4	51-1170-0	12-8020-1	14-8680-0	15-7280-0	15-8280-0	17-8990-1	19-8010-0

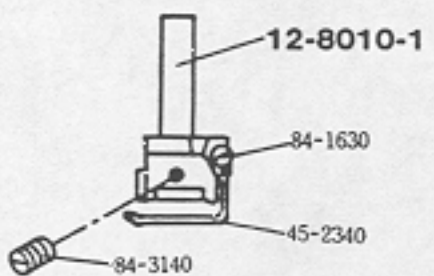
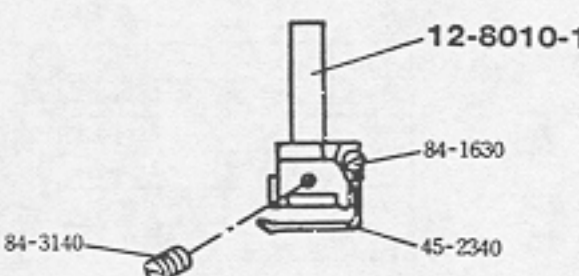
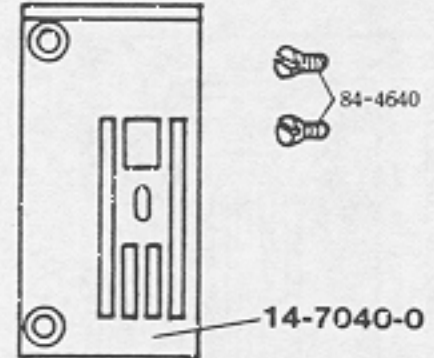
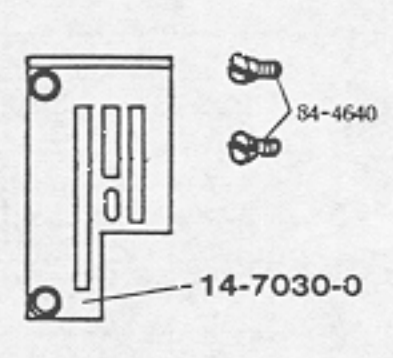
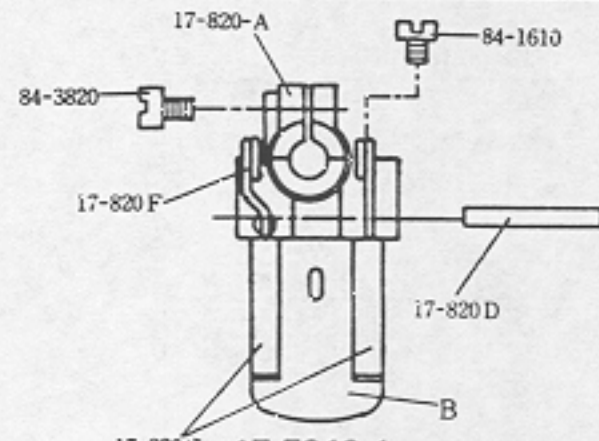
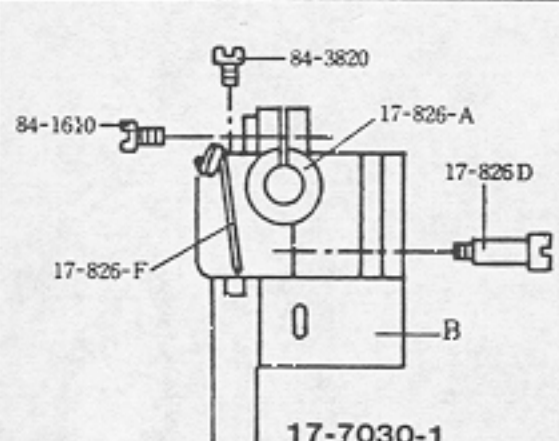
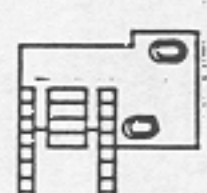
From the library of: Diamond Needle Corp

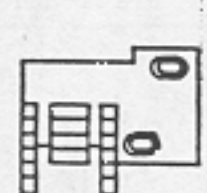
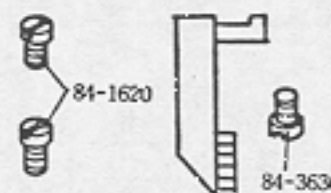
V7100D (1/8" - 1/4")	W8100D (1/8" - 1/4")																												
	<table border="1" style="width:100%; border-collapse: collapse;"> <thead> <tr> <th></th> <th>%"</th> <th>Part No.</th> <th></th> </tr> </thead> <tbody> <tr> <td rowspan="4" style="text-align: center; vertical-align: middle;">2 Needles</td> <td>1/8"</td> <td>3.17</td> <td>12-8110-1</td> </tr> <tr> <td>3/16"</td> <td>3.97</td> <td>12-8120-1</td> </tr> <tr> <td>1/4"</td> <td>4.76</td> <td>12-8130-1</td> </tr> <tr> <td>5/16"</td> <td>5.56</td> <td>12-8140-1</td> </tr> <tr> <td rowspan="3" style="text-align: center; vertical-align: middle;">3 Needles</td> <td>1/4"</td> <td>6.35</td> <td>12-8150-1</td> </tr> <tr> <td>3/8"</td> <td>5.56</td> <td>12-8010-1</td> </tr> <tr> <td>1/2"</td> <td>6.35</td> <td>12-8020-1</td> </tr> </tbody> </table>		%"	Part No.		2 Needles	1/8"	3.17	12-8110-1	3/16"	3.97	12-8120-1	1/4"	4.76	12-8130-1	5/16"	5.56	12-8140-1	3 Needles	1/4"	6.35	12-8150-1	3/8"	5.56	12-8010-1	1/2"	6.35	12-8020-1	
	%"	Part No.																											
2 Needles	1/8"	3.17	12-8110-1																										
	3/16"	3.97	12-8120-1																										
	1/4"	4.76	12-8130-1																										
	5/16"	5.56	12-8140-1																										
3 Needles	1/4"	6.35	12-8150-1																										
	3/8"	5.56	12-8010-1																										
	1/2"	6.35	12-8020-1																										
Needle holder (2,3 Needles)																													
	<table border="1" style="width:100%; border-collapse: collapse;"> <thead> <tr> <th></th> <th>%"</th> <th>Part No.</th> <th></th> </tr> </thead> <tbody> <tr> <td rowspan="4" style="text-align: center; vertical-align: middle;">2 Needles</td> <td>1/8"</td> <td>3.17</td> <td>14-7240</td> </tr> <tr> <td>3/16"</td> <td>3.97</td> <td>14-7340</td> </tr> <tr> <td>1/4"</td> <td>4.76</td> <td>14-7440</td> </tr> <tr> <td>5/16"</td> <td>5.56</td> <td>14-7540</td> </tr> <tr> <td rowspan="3" style="text-align: center; vertical-align: middle;">3 Needles</td> <td>1/4"</td> <td>6.35</td> <td>14-7640</td> </tr> <tr> <td>3/8"</td> <td>5.56</td> <td>14-8540</td> </tr> <tr> <td>1/2"</td> <td>6.35</td> <td>14-8640</td> </tr> </tbody> </table>		%"	Part No.		2 Needles	1/8"	3.17	14-7240	3/16"	3.97	14-7340	1/4"	4.76	14-7440	5/16"	5.56	14-7540	3 Needles	1/4"	6.35	14-7640	3/8"	5.56	14-8540	1/2"	6.35	14-8640	
	%"	Part No.																											
2 Needles	1/8"	3.17	14-7240																										
	3/16"	3.97	14-7340																										
	1/4"	4.76	14-7440																										
	5/16"	5.56	14-7540																										
3 Needles	1/4"	6.35	14-7640																										
	3/8"	5.56	14-8540																										
	1/2"	6.35	14-8640																										
Needle plate (2 Needles)		Needle plate (3 Needles)																											
	<table border="1" style="width:100%; border-collapse: collapse;"> <thead> <tr> <th></th> <th>%"</th> <th>Part No.</th> <th></th> </tr> </thead> <tbody> <tr> <td rowspan="4" style="text-align: center; vertical-align: middle;">3 Needles</td> <td>1/8"</td> <td>3.17</td> <td>17-7240-1</td> </tr> <tr> <td>3/16"</td> <td>3.97</td> <td>17-7340-1</td> </tr> <tr> <td>1/4"</td> <td>4.76</td> <td>17-7440-1</td> </tr> <tr> <td>5/16"</td> <td>5.56</td> <td>17-7540-1</td> </tr> <tr> <td rowspan="3" style="text-align: center; vertical-align: middle;">3 Needles</td> <td>1/4"</td> <td>6.35</td> <td>17-7640-1</td> </tr> <tr> <td>3/8"</td> <td>5.56</td> <td>17-7840-1</td> </tr> <tr> <td>1/2"</td> <td>6.35</td> <td>17-7940-1</td> </tr> </tbody> </table>		%"	Part No.		3 Needles	1/8"	3.17	17-7240-1	3/16"	3.97	17-7340-1	1/4"	4.76	17-7440-1	5/16"	5.56	17-7540-1	3 Needles	1/4"	6.35	17-7640-1	3/8"	5.56	17-7840-1	1/2"	6.35	17-7940-1	
	%"	Part No.																											
3 Needles	1/8"	3.17	17-7240-1																										
	3/16"	3.97	17-7340-1																										
	1/4"	4.76	17-7440-1																										
	5/16"	5.56	17-7540-1																										
3 Needles	1/4"	6.35	17-7640-1																										
	3/8"	5.56	17-7840-1																										
	1/2"	6.35	17-7940-1																										
Presser foot (2,3 Needles)		Presser foot (2,3 Needles)																											
	<table border="1" style="width:100%; border-collapse: collapse;"> <thead> <tr> <th></th> <th>%"</th> <th>Part No.</th> <th></th> </tr> </thead> <tbody> <tr> <td rowspan="4" style="text-align: center; vertical-align: middle;">3 Needles</td> <td>1/8"</td> <td>3.17</td> <td>15-7550</td> </tr> <tr> <td>3/16"</td> <td>3.97</td> <td>15-7550</td> </tr> <tr> <td>1/4"</td> <td>4.76</td> <td>15-7530</td> </tr> <tr> <td>5/16"</td> <td>5.56</td> <td>15-7530</td> </tr> <tr> <td rowspan="3" style="text-align: center; vertical-align: middle;">3 Needles</td> <td>1/4"</td> <td>6.35</td> <td>15-7530</td> </tr> <tr> <td>3/8"</td> <td>5.56</td> <td>15-7530</td> </tr> <tr> <td>1/2"</td> <td>6.35</td> <td>15-7530</td> </tr> </tbody> </table>		%"	Part No.		3 Needles	1/8"	3.17	15-7550	3/16"	3.97	15-7550	1/4"	4.76	15-7530	5/16"	5.56	15-7530	3 Needles	1/4"	6.35	15-7530	3/8"	5.56	15-7530	1/2"	6.35	15-7530	
	%"	Part No.																											
3 Needles	1/8"	3.17	15-7550																										
	3/16"	3.97	15-7550																										
	1/4"	4.76	15-7530																										
	5/16"	5.56	15-7530																										
3 Needles	1/4"	6.35	15-7530																										
	3/8"	5.56	15-7530																										
	1/2"	6.35	15-7530																										
Feed dog (Rear)		Feed dog (front)																											
<p>51-1180-0</p>  <p>Rear feed dog holder</p>	<p>19-8010-0</p>  <p>Looper</p>																												

From the library of: Diamond Needle Corp

V7101 D	V7101 F
 <p>12-8010-1 84-1630 45-2340 84-3140</p> <p>Needle holder</p>	 <p>12-8010-1 84-1630 45-2340 84-3140</p> <p>Needle holder</p>
 <p>84-4640 14-7040-0</p> <p>Needle plate</p>	 <p>84-4640 14-7030-0</p> <p>Needle plate</p>
 <p>17-820-A 84-3820 17-820 F 17-820 D 17-820 C 17-7040-1 B 84-1610</p> <p>Presser foot</p>	 <p>84-3820 84-1610 17-826-A 17-826 D 17-826 F B 17-7030-1</p> <p>Presser foot</p>
 <p>15-7540-0 Feed dog (Rear)</p>  <p>84-1620 84-3630 15-7240-0 Feed dog (front)</p>	 <p>15-7570-0 Feed dog (Rear)</p>  <p>84-1620 84-3630 15-7260-0 Feed dog (front)</p>
 <p>51-1180-0 Rear feed dog holder</p>  <p>19-8010-0 Looper</p>	 <p>51-1170-0 Rear feed dog holder</p>  <p>19-8010-0 Looper</p>

From the library of: Diamond Needle Corp

W8100C (3/8"-1/4")

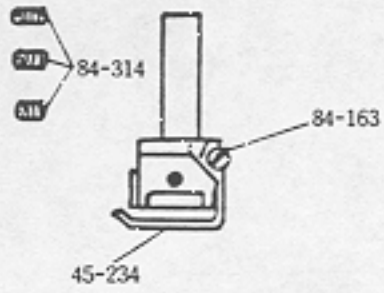

Needle holder (2,3 Needles)

	%"	Part No.	
3/8"	4.76	12-8130-1	2 Needles
5/8"	5.56	12-8140-1	2 Needles
1/4"	6.35	12-8150-1	2 Needles
3/8"	5.56	12-8010-1	3 Needles
1/4"	6.35	12-8020-1	3 Needles

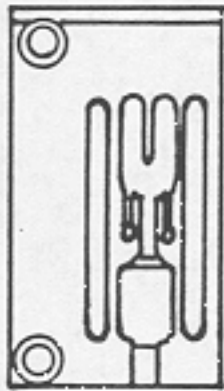

Needle plate (2,3 Needles)

	%"	Part No.	
3/8"	4.76	14-8030	2 Needles
5/8"	5.56	14-8040	2 Needles
1/4"	6.35	14-8050	2 Needles
3/8"	5.56	14-8010	3 Needles
1/4"	6.35	14-8020	3 Needles

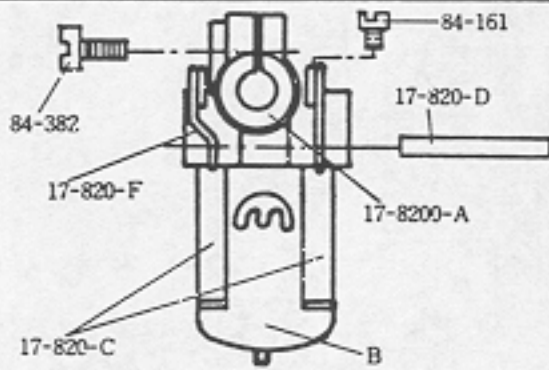

Presser foot (2,3 Needles)

	%"	Part No.	
3/8"	4.76	17-8470-1	2 Needles
5/8"	5.56	17-8570-1	2 Needles
1/4"	6.35	17-8670-1	2 Needles
3/8"	5.56	17-8870-1	3 Needles
1/4"	6.35	17-8970-1	3 Needles

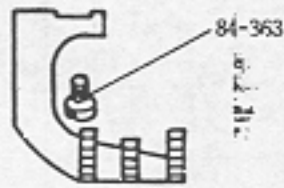

15-7610-0

Feed dog (front)

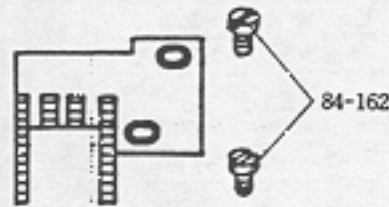

15-7310-0

Feed dog (Rear)

51-1180-0



Feed dog holder

19-8010-0

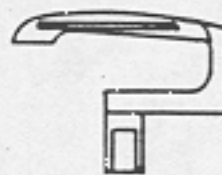

Looper

From the library of: Diamond Needle Corp

V7102F (3/8"-1/4"), W8102F (3/8"-1/4")

V7103F (3/8"-1/4"), W8103F (3/8"-1/4")

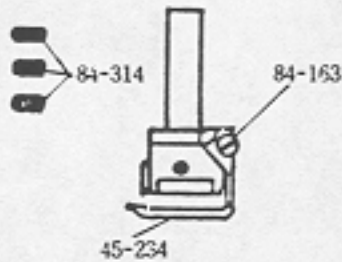

Needle holder (2,3 Needles)

	%	Part No.	
2 Needles	3/8"	3.17	12-8110-1
	5/8"	3.97	12-8120-1
	3/4"	4.76	12-8130-1
	7/8"	5.56	12-8140-1
	1"	6.35	12-8150-1
3 Needles	5/8"	5.56	12-8010-1
	3/4"	6.35	12-8020-1

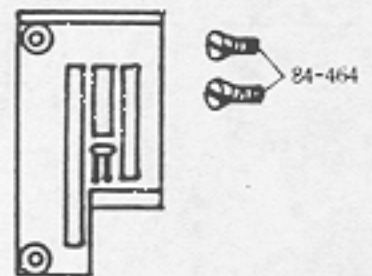

Needle plate (2 Needles)

	%	Part No.	
2 Needles	3/8"	3.17	14-7260
	5/8"	3.97	14-7360
	3/4"	4.76	14-7460
	7/8"	5.56	14-7560
	1"	6.35	14-7660
3 Needles	5/8"	5.56	14-8560
	3/4"	6.35	14-8660

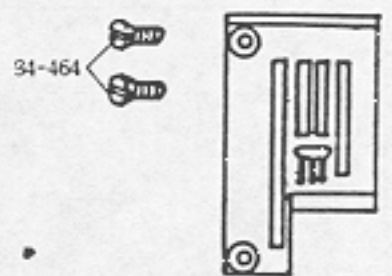

Needle plate (3 Needles)

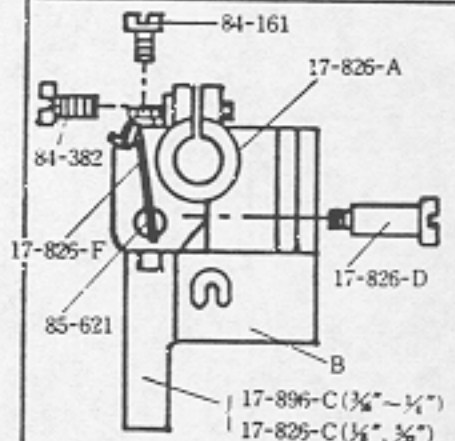

Presser foot (2 Needles)

	%	Part No.	
2 Needles	3/8"	3.17	17-8260-1
	5/8"	3.97	17-8360-1
	3/4"	4.76	17-8460-1
	7/8"	5.56	17-8560-1
	1"	6.35	17-8660-1
3 Needles	5/8"	5.56	17-8860-1
	3/4"	6.35	17-8960-1

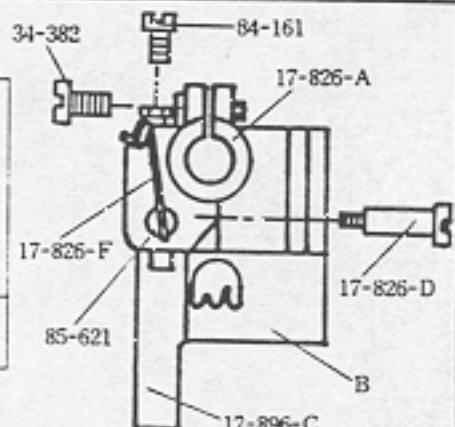

Presser foot (3 Needles)

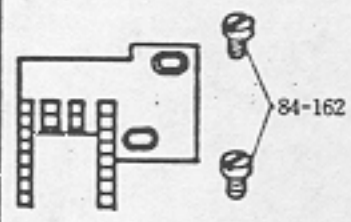

Feed dog (Rear)

	%	Part No.
3/8"	3.17	15-7550-0
5/8"	3.97	15-7580-0
3/4"	4.76	15-7560-0
7/8"	5.56	15-7560-0
1"	6.35	15-7560-0
* 5/8"	5.56	15-7560-0
* 3/4"	6.35	15-7560-0

\* 3 Needles

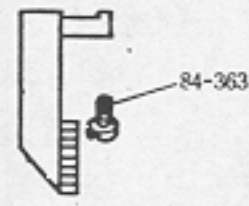

Feed dog (Front)

	%	Part No.
3/8"	3.17	15-7290-0
5/8"	3.97	15-7290-0
3/4"	4.76	15-7270-0
7/8"	5.56	15-7270-0
1"	6.35	15-7270-0
* 5/8"	5.56	15-7270-0
* 3/4"	6.35	15-7270-0

\* 3 Needles

51-1170-0



Rear feed dog holder

19-8010-0



Looper

From the library of: Diamond Needle Corp

V7100DE

W8100DE

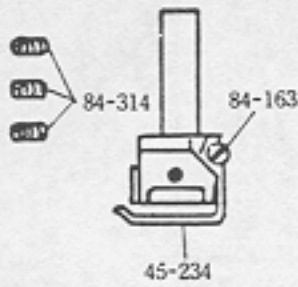

	№	Part No.	
2 Needles	1/8"	3.17	12-8110-1
	3/16"	3.97	12-8120-1
	1/4"	4.76	12-8130-1
	5/16"	5.56	12-8140-1
3 Needles	1/4"	6.35	12-8150-1
	5/16"	5.56	12-8010-1
	3/8"	6.35	12-8020-1

Needle holder (2,3 Needles)

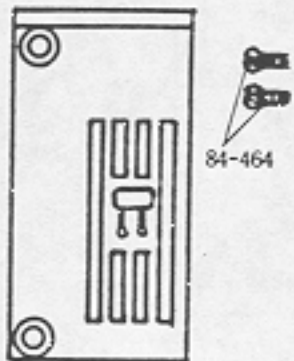

	№	Part No.	
2 Needles	1/8"	3.17	14-7250
	3/16"	3.97	14-7350
	1/4"	4.76	14-7450
	5/16"	5.56	14-7550
3 Needles	1/4"	6.35	14-7650
	5/16"	5.56	14-8550
	3/8"	6.35	14-8650

Needle plate (2 Needles)

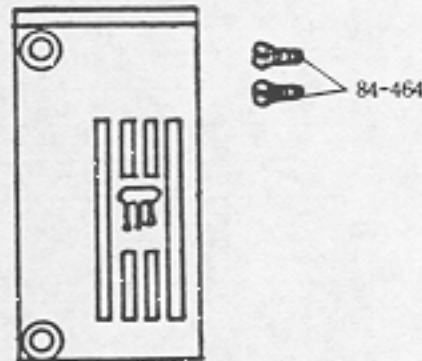

Needle plate (3 Needles)

	№	Part No.	
* 3 Needles	1/8"	3.17	17-7250-1
	3/16"	3.97	17-7350-1
	1/4"	4.76	17-7450-1
	5/16"	5.56	17-7550-1
* 3 Needles	1/4"	6.35	17-7650-1
	5/16"	5.56	17-7850-1
	3/8"	6.35	17-7950-1

Presser foot (2.3 Needles)

	№	Part No.	
* 3 Needles	1/8"	3.17	17-8250-1
	3/16"	3.97	17-8350-1
	1/4"	4.76	17-8450-1
	5/16"	5.56	17-8550-1
* 3 Needles	1/4"	6.35	17-8650-1
	5/16"	5.56	17-8850-1
	3/8"	6.35	17-8950-1

Presser foot (2.3 Needles)

	№	Part No.	
* 3 Needles	1/8"	3.17	15-7550-0
	3/16"	3.97	15-7550-0
	1/4"	4.76	15-7530-0
	5/16"	5.56	15-7530-0
	1/4"	6.35	15-7530-0
	5/16"	5.56	15-7530-0
3/8"	6.35	15-7530-0	

Feed dog (Rear)

	№	Part No.	
* 3 Needles	1/8"	3.17	15-7240-0
	3/16"	3.97	15-7240-0
	1/4"	4.76	15-7230-0
	5/16"	5.56	15-7230-0
	1/4"	6.35	15-7230-0
	5/16"	5.56	15-7230-0
3/8"	6.35	15-7230-0	

Feed dog (front)

51-1180-0



Rear feed dog holder

19-8010-0



Looper

From the library of: Diamond Needle Corp



V7102EMK (3/8" - 1/4")

W8103EMK (3/8", 1/4")

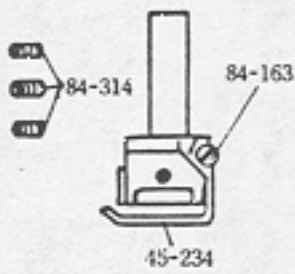

	%"	Part No.	
2 Needles	3/8"	12-8110-1	
	3/8"	12-8120-1	
	3/8"	12-8130-1	
	3/8"	12-8140-1	
3 Needles	1/4"	12-8150-1	
	3/8"	12-8010-1	
	1/4"	12-8020-1	

Needle holder (2,3 Needles)

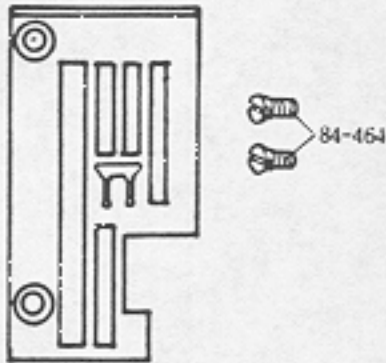

	%"	Part No.	
2 Needles	3/8"	14-7280	
	3/8"	14-7380	
	3/8"	14-7480	
	3/8"	14-7580	
3 Needles	1/4"	14-7680	
	3/8"	14-8580	
	1/4"	14-8680	

Needle plate (2 Needles)

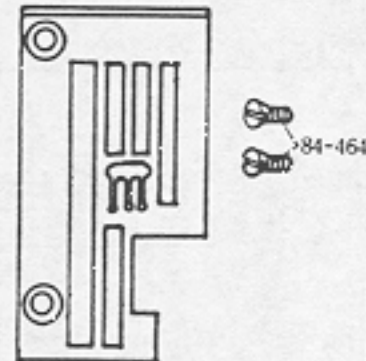

Needle plate (3 Needles)

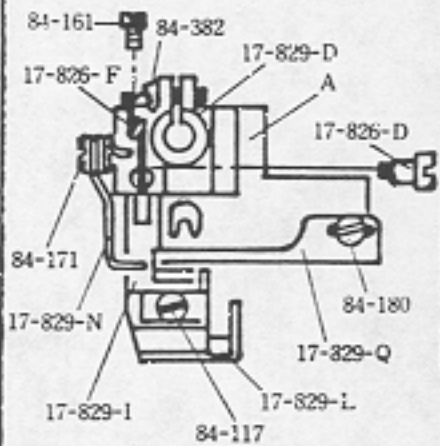

	%"	Part No.	
2 Needles	3/8"	17-8290-1	
	3/8"	17-8390-1	
	3/8"	17-8490-1	
	3/8"	17-8590-1	
3 Needles	1/4"	17-8690-1	
	3/8"	17-8890-1	
	1/4"	17-8990-1	

Presser foot (2 Needles)

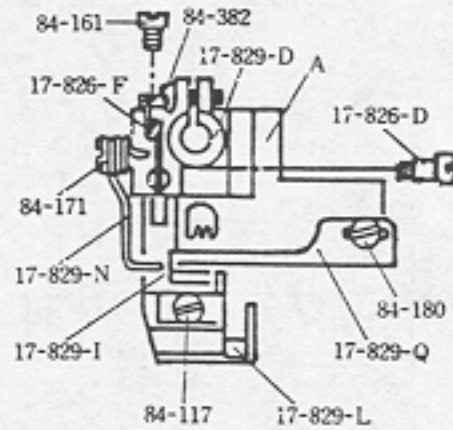

Presser foot (3 Needles)

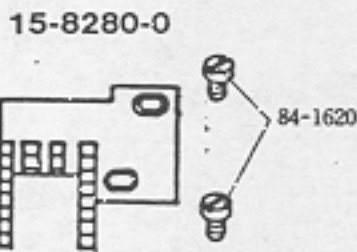

Feed dog (Rear)

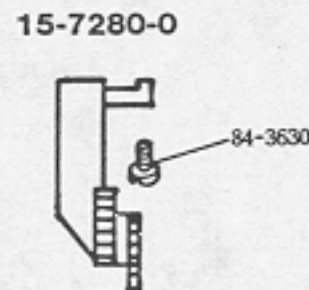

Feed dog (Front)



Rear feed dog holder

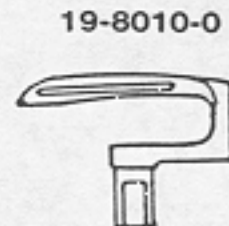

Looper

From the library of: Diamond Needle Corp

# 16. Accessories (アクセサリー)

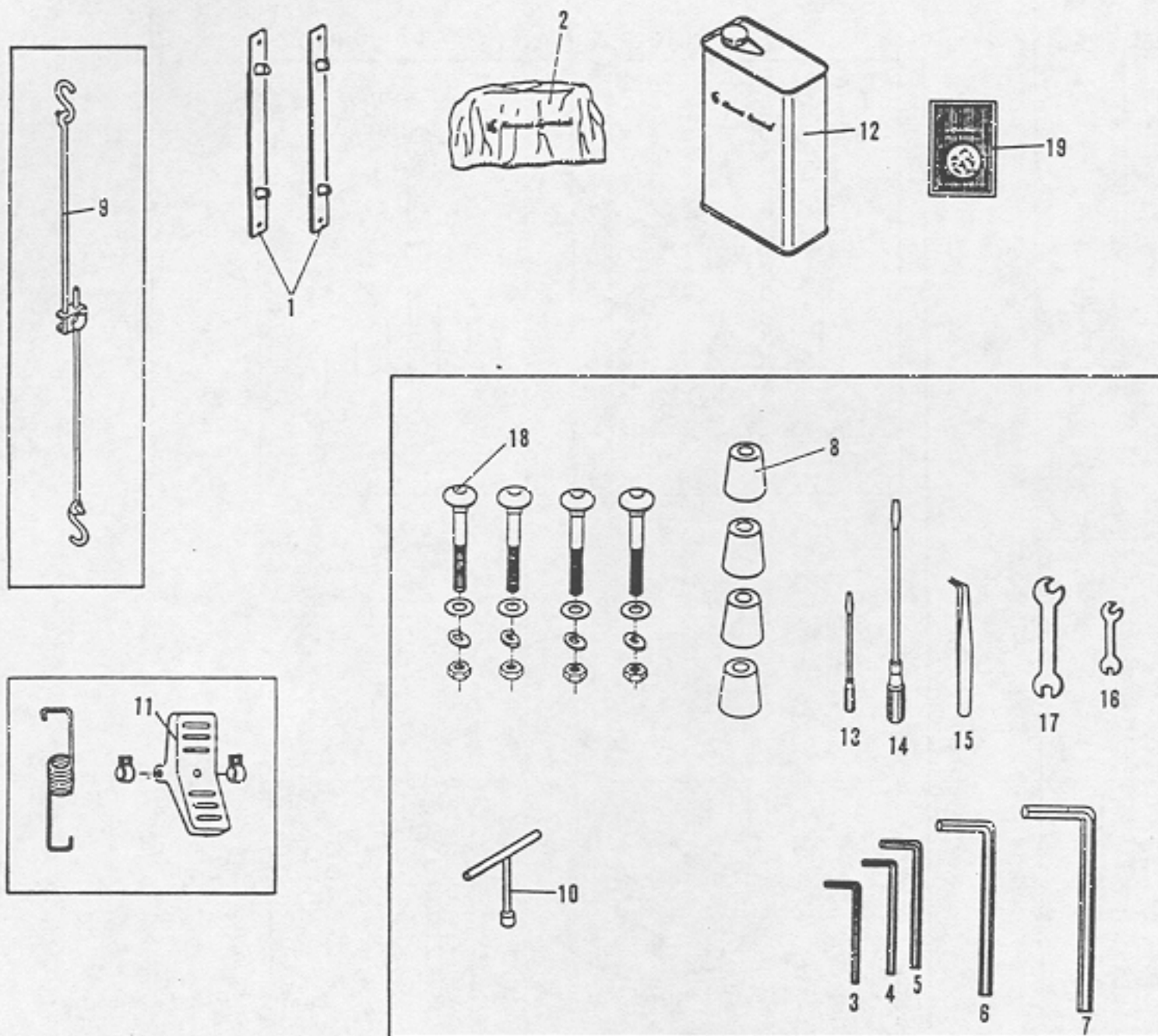

90-9000-3

From the library of: Diamond Needle Corp

No.	Part No.	Part name	品名	Q. ty
1	25-1400-0	Machine mount bracket	タンク取付全具	2
2	28-0210-0	Machine cover	ミシン頭部ビニールカバー	1
3	28-3100-0	Wrench	6角レンチ 1.5	1
4	28-3110-0	Wrench A	6角レンチ A	1
5	28-3120-0	Wrench B	6角レンチ B	1
6	28-3130-0	Wrench C	6角レンチ C	1
7	28-3140-0	Wrench D	6角レンチ D	1
8	31-1630-0	Cushion rubber	クッションゴム	4
9	77-0060-2	Tie-rod (upper)	連結棒	1
10	28-4640-0	Wrench T	T型レンチ 10ミリ	1
11	77-0010-2	Pedal	押え揚げペダル	1
12	28-6110-0	Oil tellesso	ミシンオイル	1
13	28-4510-0	Screw driver (small)	ドライバー小	1
14	28-4520-0	Screw driver	ドライバー大	1
15	28-0110-0	Tweezers	ピンセット	1
16	28-4210-0	Spanner (small)	スパナ小	1
17	28-4220-0	Spanner (large)	スパナ大	1
18	80-7510-0	Screw	クラッチモーター取付ネジ	4
19	13-0110-6	Needle UY-128GAS #11	針	10
	13-0710-6	Needle DV-63 #11 (EMK Type)	針 (EMK Type)	10

# 17. Thread stand (糸立て)

V7103

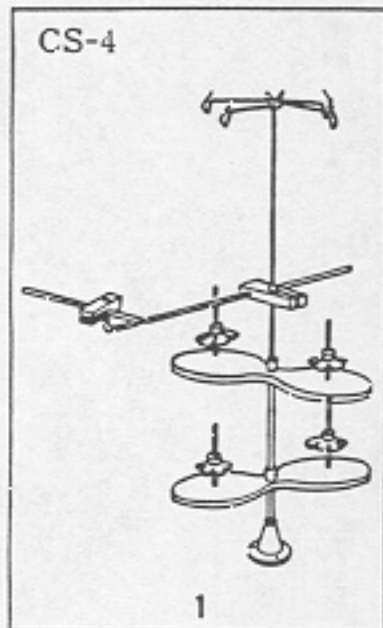

V7102

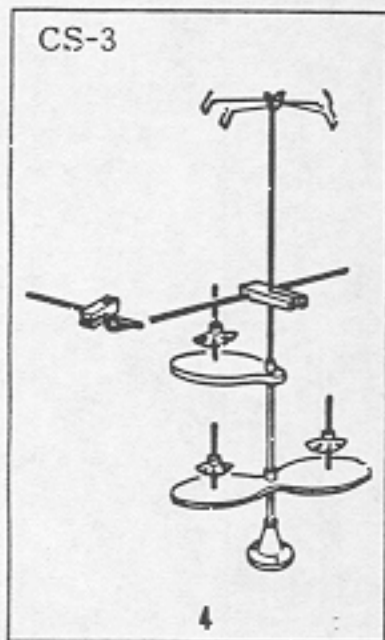

V7101

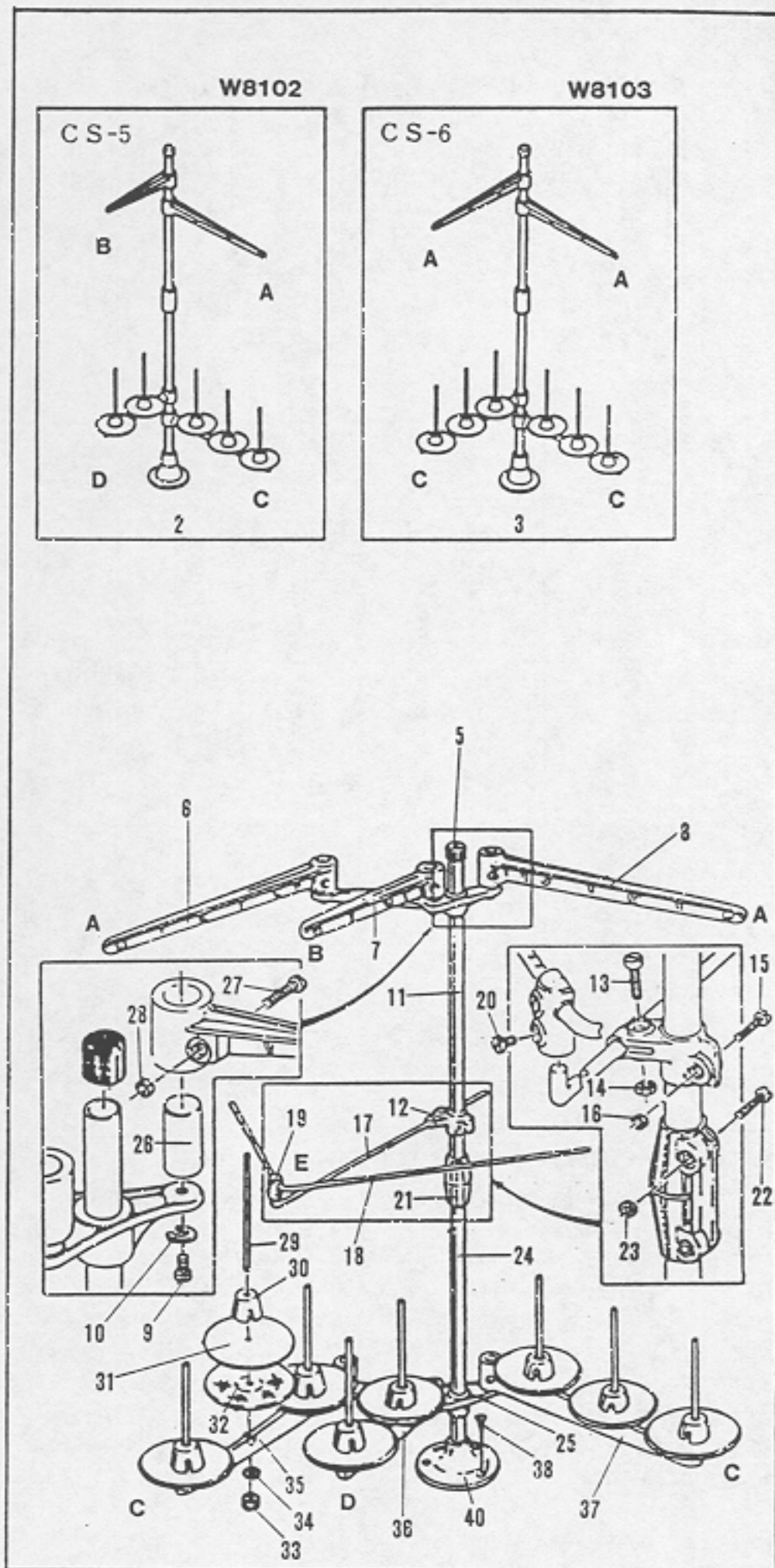
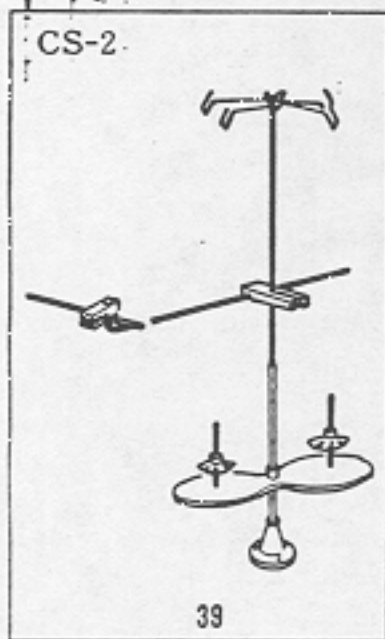

From the library of: Diamond Needle Corp

No.	Part No.	Part name	品 名	Q, ty
1	42-0040-0	Thread stand (4) CS-4	4本糸立て	1set
2	42-0050-0	Thread stand (5) CS-5	5本糸立て	1set
3	42-0060-0	Thread stand (6) CS-6	6本糸立て	1set
4	42-0030-0	Thread stand (3) CS-3	3本糸立て	1set
5	42-1200-0	Cap	キャップ	1
6	42-1160-0	Thread guide bracket (3)	糸立て台ブラケット (3)	
7		Thread guide bracket (2)	糸立て台ブラケット (2)	
8		Thread guide bracket (3)	糸立て台ブラケット (3)	
9		Screw	ネ ジ	6
10		Washer	ワッシャ	6
11	42-1130-0	Bar (upper)	糸立て支柱	1
12		Shank	シャンク	1
13		Screw	ネ ジ	1
14		Nut	ナット	1
15		Screw	ネ ジ	1
16		Nut	ナット	1
17		Thread eyelet guide arm bar	糸ガイド棒	1
18		Thread eyelet guide	糸 道	1
19		Joint	継 手	1
20		Screw	ネ ジ	2
21		Joint	継 手	1
22		Screw	ネ ジ	2
23		Nut	ナット	2
24	42-1120-0	Bar (low)	糸立て支柱	1
25		Base	糸立て土台	2
26		Mounting bracket	取付ブラケット	6
27		Screw	ネ ジ	
28		Nut	ナット	
29		Spool pin	糸立てピン	
30		Spool pin retaining fin	糸立て固定具	
31	42-1190-0	Spool mat	クッション	
32	42-1230-0	Spool tray	糸受け皿	
33		Nut	ナット	
34		Washer	ワッシャ	
35	42-1150-0	Spool pin bracket (3)	FPL ミツ穴	
36		Spool pin bracket (2)	FPL ニツ穴	
37	42-1150-0	Spool pin bracket (3)	FPL ミツ穴	
38	42-1220-0	Screw	ネ ジ	3
39	42-0020-0	Thread stand (2) CS-2	2本糸立て	1set
40	42-1810-0	Base	糸立て土台	1

From the library of: Diamond Needle Corp

# 18. Table assembly diagram (テーブル図) EMK Type

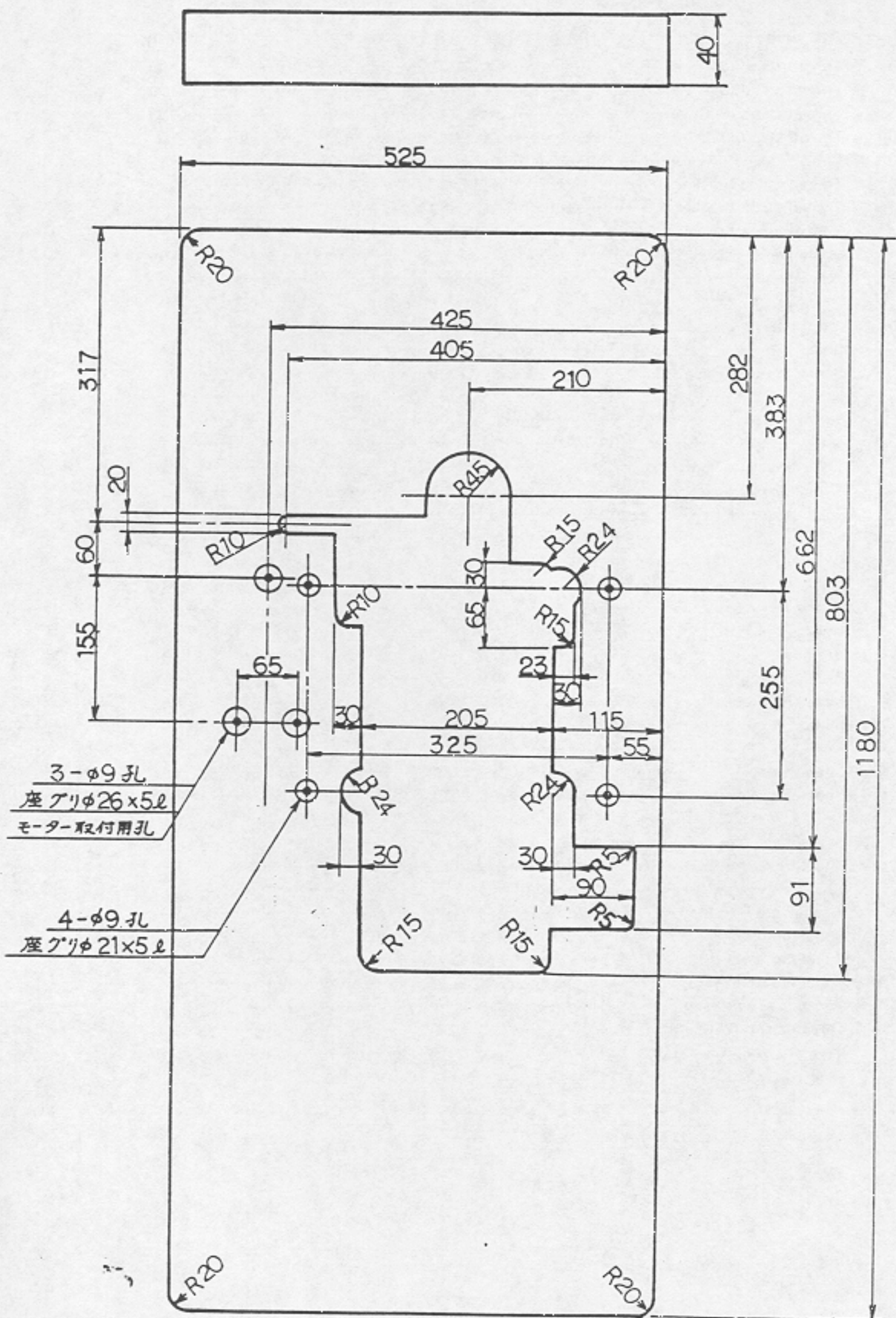

From the library of: Diamond Needle Corp



19. Table stand assembly diagram (テーブルスタンド据付図)

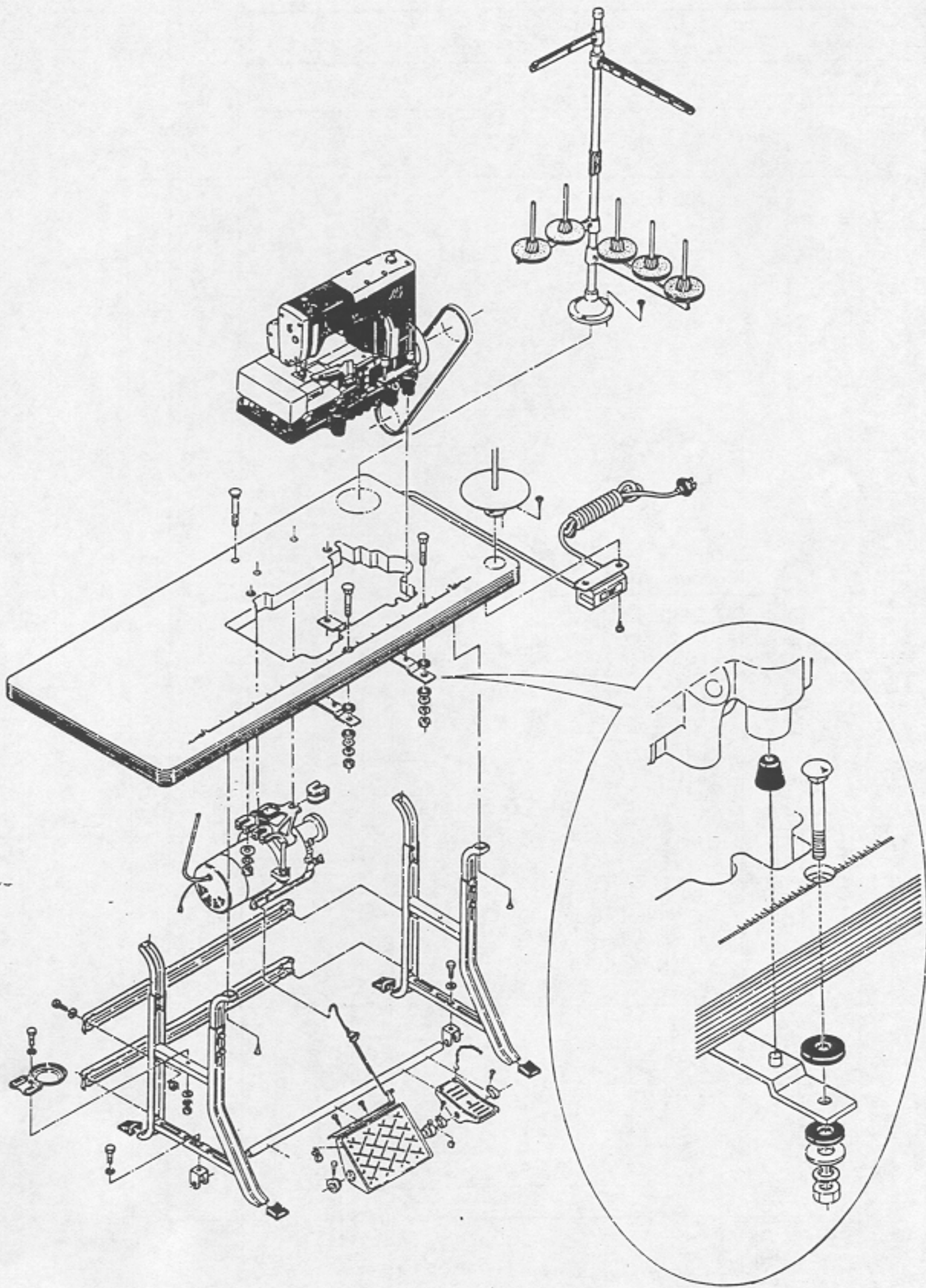

From the library of: Diamond Needle Corp

## 20. Index (索引)

Part No.	Q.ty	Page No.	Part No.	Q.ty	Page No.	Part No.	Q.ty	Page No.	Part No.	Q.ty	Page No.
01-0450-0	1	26	12-8120-1	1	32	15-7230-0	1	32	17-8260-A	1	31
-7120-0	1	26	-8120-1	1	33	-7240-0	1	28	-8260-C	1	31
-7140-0	1	25	-8130-1	1	28	-7240-0	1	29	-8260-D	1	29
-7320-0	1	26	-8130-1	1	30	-7240-0	1	32	-8260-D	1	31
-8050-0	2	25	-8130-1	1	31	-7260-0	1	29	-8260-F	1	29
-806G-0	1	25	-8130-1	1	32	-7270-0	1	31	-3260-F	1	31
-8160-0	2	5	-8130-1	1	33	-7270-0	1	33	-8290-1	1	33
-8370-0	4	25	-8140-1	1	28	-7290-0	1	31	-8290-D	1	33
-8510-0	1	26	-8140-1	1	30	-7310-0	1	30	-8290-I	1	33
-8520-0	1	26	-8140-1	1	31	-7530-0	1	28	-8290-L	1	33
-8530-0	1	26	-8140-1	1	32	-7530-0	1	32	-8290-N	1	33
-8540-0	1	26	-8140-1	1	33	-7540-0	1	29	-8290-Q	1	33
-8550-0	1	26	-8150-1	1	28	-7550-0	1	28	-8290-S	1	33
-8560-0	1	26	-8150-1	1	30	-7550-0	1	32	-8340-1	1	28
-8570-0	1	26	-8150-1	1	31	-7560-0	1	31	-8350-1	1	32
-8580-0	2	26	-8150-1	1	32	-7560-0	1	33	-8360-1	1	31
-8590-0	1	26	-8150-1	1	33	-7570-0	1	29	-8390-1	1	33
-860G-0	1	26				-7580-0	1	31	-8440-1	1	28
-861G-0	1	26	13-0110-6	10	34	-7610-0	1	30	-8450-1	1	32
									-8460-1	1	31
02-0490-0	6	26	14-0310-2	1	2	17-7030-1	1	29	-8470-1	1	30
-1010-0	2	26	-7030-0	1	29	-7040-1	1	29	-8490-1	1	33
-1180-0	1	26	-7040-0	1	29	-7240-1	1	28	-8540-1	1	28
-4030-0	1	26	-7240-0	1	28	-7250-1	0	32	-8550-1	1	32
			-7250-0	1	32	-7250-A	1	32	-8560-1	1	31
04-8010-0	1	20	-7260-0	1	31	-7250-C	1	32	-8570-1	1	30
-8020-0	1	20	-7280-0	1	33	-7250-D	1	32	-8590-1	1	33
			-9340-0	1	28	-7250-E	1	32	-8640-1	1	28
07-001G-0	1	24	-7350-0	1	32	-7250-F	1	32	-8650-1	1	32
-1470-0	1	24	-7360-0	1	31	-7250-G	1	32	-8660-1	1	31
-1490-0	1	24	-7380-0	1	33	-7340-1	1	28	-8670-1	1	30
-1660-0	1	24	-7440-0	1	28	-7350-1	1	32	-8690-1	1	33
-1670-0	1	24	-7450-0	1	32	-7440-1	1	28	-8840-1	1	28
-1690-0	1	24	-7460-0	1	31	-7450-1	1	32	-8850-1	1	32
-1700-0	1	24	-7480-0	1	33	-7540-1	1	28	-8860-1	1	31
-1820-0	1	24	-7540-0	1	28	-7550-1	1	32	-8870-1	1	30
-183G-0	1	24	-7550-0	1	32	-7640-1	1	28	-8890-1	1	33
-815W-2	1	24	-7560-0	1	31	-7650-1	1	32	-8940-1	1	28
			-7580-0	1	33	-7840-1	1	28	-8950-1	1	32
11-8010-0	1	10	-7640-0	1	28	-7850-1	1	32	-8960-1	1	31
			-7650-0	1	32	-7940-1	1	28	-8960-C	1	31
12-8010-1	1	28	-7660-0	1	31	-7950-1	1	32	-8970-1	1	30
-8010-1	1	29	-7680-0	1	33	-8200-A	1	28	-8990-1	1	33
-8010-1	1	30	-8010-0	1	30	-8200-A	1	30			
-8010-1	1	31	-8020-0	1	30	-8200-A	1	30	18-7050-0	1	14
-8010-1	1	32	-8030-0	1	30	-8200-C	1	28	-7090-0	1	14
-8010-1	1	33	-8040-0	1	30	-8200-C	1	29	-7190-0	1	14
-8020-1	1	28	-8050-0	1	30	-8200-C	1	30	-7200-0	1	14
-8020-1	1	30	-8540-0	1	28	-8200-D	1	28	-7220-0	1	16
-8020-1	1	31	-8550-0	1	32	-8200-D	1	29	-7250-0	1	16
-8020-1	1	32	-8560-0	1	31	-8200-D	1	30			
-8020-1	1	33	-8580-0	1	33	-8200-F	1	28	19-3090-0	1	16
-8110-1	1	28	-8640-0	1	28	-8200-F	1	29	-3490-0	1	16
-8110-1	1	31	-8650-0	1	32	-8200-F	1	30	-8010-0	1	28
-8110-1	1	32	-8660-0	1	31	-8240-1	1	28	-8010-0	1	29
-8110-1	1	33	-8680-0	1	33	-8250-1	1	32	-8010-0	1	29
-8120-1	1	28				-8260-1	1	31	-8010-0	1	30
-8120-1	1	31	15-7230-0	1	28	-8260-A	1	29	-8010-0	1	31

From the library of: Diamond Needle Corp



Part No.	Q,ty	Page No.	Part No.	Q,ty	Page No.	Part No.	Q,ty	Page No.	Part No.	Q,ty	Page No.
19-8010-0	1	32	23-9110-0	4	8	35-1070-0	1	8	41-237B-0	1	5
-8010-0	1	33	9130-0	1	2	-1220-0	1	8	-3040-0	1	4
-8070-0	1	20			-1610-0	1	8	-4160-0	1	4	
			24-1030-0	1	10	-2030-0	2	8	-7010-0	2	5
20-532G-0	1	4			-2040-1	1	8	-7010-0	3	5	
-6040-0	1	24	25-1010-0	1	24	-2470-0	1	8	-7020-0	1	5
-805W-0	1	2	-1020-0	1	24	-3140-0	1	8	-7020-0	2	5
			-108W-0	1	2	-3150-0	1	8	-7210-0	1	4
21-1000-0	1	2	-108W-0	1	24	-3170-0	2	8	42-0020-0	1	36
-122G-0	1	2	-108W-0	2	2	-3180-0	1	8	-0030-0	1	36
-183W-0	1	2	-1400-0	2	34				-0040-0	1	36
-1850-0	1	2	-8010-0	2	24	-3240-0	2	8	-0050-0	1	36
-1910-0	1	2	-8010-0	2	24	-3140-0	1	8	-0060-0	1	36
-1910-0	1	22	-8010-0	3	2	-3430-0	1	8	-1120-0	1	36
-192W-0	1	2	-8010-0	5	2	-4120-0	5	8	-1130-0	1	36
-212W-0	1	2			-8220-0	1	8	-1150-0		36	
-350W-0	1	24	26-7060-0	1	22	-8290-0	1	8	-1150-0		36
-352W-0	1	2	-7120-0	1	2	-8310-0	1	8	-1160-0		36
-4020-0	1	2	-7240-0	1	22	-8320-0	2	8	-1810-0		36
-4430-0	1	2	-7250-0	1	22	-8390-0	1	8	-1190-0		36
-443W-0	1	24	-7510-0	1	22	-9150-0	1	2	-1200-0	1	36
-4980-0	1	2	-7520-0	1	22				-1220-0		36
-5210-0	1	2	-7530-0	2	22	39-1370-0	1	2	-1230-0		36
-5210-0	1	24	-7610-0	1	22	-1380-0	1	8	43-3380-0	1	4
-7030-0	1	2	-7620-0	1	24	-1390-0	1	8	-3420-0	1	4
-7120-0	1	2	-8660-0	1	22	-1670-0	1	2	-3440-0	1	4
-7210-0	1	2	-8670-0	2	22	-2160-0	1	2			
-723W-0	1	24	-8690-0	2	22	-2330-0	1	2	45-0810-0	1	4
-816W-0	1	24	-8760-0	1	22	-8010-0	1	6	-0910-0	1	4
-817G-0	1	26	-8770-0	2	22	-8030-0	1	6	-0940-0	1	4
			-8780-0	1	22	-8060-0	1	6	-0960-0	1	4
22-872W-0	1	2	-8790-0	1	22	-8100-0	1	16	-1000-0	1	4
-883W-0	1	2							-1420-0	1	4
			27-5310-0	1	4	41-101W-0	3	5	-1690-0	1	4
23-1200-0	4	2	-5330-0	1	4	-101W-0	4	5	-1810-0	1	4
-1590-0	1	2	-5340-0	1	4	-101W-0	5	5	-1810-0	1	10
-1600-0	3	8			-105W-0	3	5	-2340-0	1	28	
-1640-0	1	8	28-0110-0	1	34	-105W-0	4	5	-2340-0	1	29
-1640-0	1	8	-0210-0	1	34	-105W-0	5	5	-2340-0	1	30
-1750-0	1	2	-3100-0	1	34	-107W-0	3	5	-2340-0	1	31
-1870-0	1	4	-3110-0	1	34	-107W-0	4	5	-2340-0	1	32
-1870-0	1	4	-3120-0	1	34	-107W-0	5	5	-2460-0	1	4
-1970-0	1	13	-3130-0	1	34	-1110-0	6	5	-2510-0	1	4
-2290-0	1	2	-3140-0	1	34	-1110-0	8	5	-9140-0	1	4
-2340-0	1	2	-4210-0	1	34	-1110-0	10	5	-9230-0	1	4
-2390-0	1	2	-4220-0	1	34	-1150-0	3	5			
-2960-0	1	6	-4510-0	1	34	-1150-0	4	5	47-1310-0	1	4
-3040-0	1	2	-4520-0	1	34	-1150-0	5	5	-1320-0	1	4
-3060-0	4	8	-4640-0	1	34	-1170-0	3	5	-1440-0	2	4
-3110-0	1	18	-6110-0	1	34	-1170-0	4	5	-1490-0	1	4
-3240-0	3	5	-7010-0	1	24	-1170-0	5	5	-2020-0	1	4
-3240-0	4	5				-1310-0	3	5	-2030-0	1	4
-3240-0	5	5	30-0150-0	1	8	-1310-0	4	5			
-3410-0	1	16	-5000-0	1	8	-1310-0	5	5	49-1390-0	1	13
-3410-0	1	26				-1510-0	1	4			
-3410-0	2	13	31-1630-0	4	34	-1530-0	1	4	51-0130-0	1	13
-3410-0	2	14	-2190-0	1	2	-1540-0	1	4	-0310-0	1	13
-3430-0	1	8	-2220-0	1	8	-1550-0	2	4	-0360-0	1	13
-3910-0	1	14	-2490-0	1	8	-1560-0	2	4	-1020-0	1	14
-3910-0	1	14	-3140-0	3	8	-1570-0	1	4	-1030-0	1	14
-3930-0	1	13	-3640-0	1	8	-1720-0	3	5	-1050-0	1	14
-8000-0	1	6	-4090-0	1	8	-1720-0	4	5	-1090-0	1	14
-8030-0	1	2	-4100-0	1	12	-1720-0	5	5	-1110-0	2	14
-8100-0	1	16	-4380-0	1	16	-236B-0	1	5	-1130-0	1	14

From the library of: Diamond Needle Corp

Part No.	Q,ty	Page No.	Part No.	Q,ty	Page No.	Part No.	Q,ty	Page No.	Part No.	Q,ty	Page No.
51-1170-0	1	29	69-8030-0	1	6	75-2490-0	2	10	77-8880-0	1	18
-1170-0	1	31				-3060-0	2	10			
-1170-0	1	33	71-1190-0	1	2	-3210-0	1	24	79-0420-0	1	18
-1180-0	1	28	-1650-0	1	24	-3220-0	1	12	-0440-0	12	26
-1180-0	1	29	-2010-0	1	16	-3320-0	1	12	-0600-0	4	12
-1180-0	1	30	-2020-0	2	4	-3560-0	1	10	-1230-0	1	18
-1180-0	1	32	-2160-0	1	16	-3560-0	1	20	-1420-0	1	18
-1200-0	1	14	-2160-0	2	6	-3700-0	1	16	-1420-0	1	24
			-2510-0	2	2	-3720-0	2	14	-1580-0	1	25
60-3810-0	1	10	-2590-0	1	24	-3720-0	2	16	-2270-0	1	18
-7240-0	1	14	-3010-0	1	2	-3720-0	2	18	-2280-0	1	4
			-3080-0	1	2	-3810-0	2	10	-2330-0	1	2
61-2550-U	1	24	-3080-0	1	24	-3880-0	2	10	-2330-0	1	24
-2600-0	1	26	-3080-0	2	2	-3980-0	1	20	-2330-0	2	2
-2610-0	1	26	-3220-0	1	16	-4000-0	1	26	-5010-0	1	2
-3140-0	1	13	-3260-0	1	18	-4010-0	1	16	-5010-0	1	24
-3220-0	1	13	-4010-0	1	2	-4070-0	2	26	-5020-0	1	2
-4030-0	1	26	-4010-0	1	24	-4090-0	1	26	-5020-0	1	24
-5130-U	2	16	-4130-0	1	14	-4360-0	1	18	-6010-0	1	16
-5140-0	1	12	-4310-0	2	13	-4460-0	1	24			
-7130-U	1	12	-4540-0	1	16	-4490-0	3	16	80-7510-0	4	34
-8010-U	1	20	-4550-0	1	20	-4510-0	1	18			
-8020-U	1	20	-4550-0	2	10	-4520-0	2	2	81-0810-0	1	6
-8410-U	1	24	-4660-0	6	26	-4530-0	3	26	-0820-0	2	6
			-5010-0	2	10	-4550-0	1	14	-1410-0	2	14
63-2060-0	1	26	-5050-0	1	25	-4550-0	1	4	-1490-0	1	6
-2110-0	1	24	-5060-0	1	10	-4550-0	2	2	-1620-0	1	6
-2320-U	2	13	-5310-0	1	14	-4550-0	2	22	-1630-0	1	6
-3570-0	1	14	-5430-0	1	18	-4550-0	2	4	-2060-0	1	6
-5250-1	1	20	-5530-0	1	20				-2090-0	1	6
-8110-1	1	16	-0450-0	1	18	-4560-0	2	22	-2360-0	1	6
-8110-1	1	24	-5610-0	1	18	-4580-0	1	14	-2370-0	1	6
-8120-1	1	16	-6130-0	1	12	-4580-0	1	16	-2390-0	1	6
-8130-1	1	16	-6470-0	1	14	-4600-0	1	16	-3280-0	1	26
-8210-U	1	16	-6930-0	1	10	-4670-0	1	14	-3290-0	1	26
			-7850-0	1	13	-4680-0	3	4	-7140-0	1	6
65-4020-0	1	16	-7870-0	1	14	-4680-0	3	24	-7200-0	1	6
-4350-0	1	16	-7870-0	1	24	-4700-0	1	8	-7350-0	2	6
-5070-1	1	24	-8010-0	1	26	-4700-0	3	8	-7530-0	2	6
-9020-0	1	16	-8020-0	1	26	-5220-0	2	10	-8030-0	1	6
			-8110-0	1	16	-5220-0	4	10	-8070-0	1	6
66-5060-0	1	14	-8870-0	1	10	-5270-0	4	26	-8080-0	1	6
-8010-0	1	10	-8870-0	1	12	-5520-0	1	10	-8100-0	2	16
-8020-0	1	10	-8890-0	1	10	-5520-0	1	20	-8120-0	1	26
			-8890-0	1	26	-8110-0	1	16			
67-1320-1	1	14				-8140-0	1	26	84-1010-0	2	26
-1820-0	1	24	75-1010-0	1	12	-8140-0	2	12	-1120-0	1	16
-2290-1	1	16	-1060-0	2	10	-8880-0	1	18	-1120-0	1	4
-3140-0	1	14	-1070-1	1	12				-1120-0	2	22
-3760-U	1	12	-1140-1	1	13	77-0010-2	1	34	-1150-0	1	16
-8010-0	1	10	-1300-0	1	18	-0060-2	1	34	-1170-0	1	33
-8020-0	1	10	-1320-1	1	14	-1010-0	1	18	-1610-0	1	2
-8030-1	1	10	-1390-1	1	16	-1020-0	1	18	-1610-0	1	16
-8040-0	1	20	-1520-1	1	10	-1030-0	1	18	-1610-0	1	29
-8050-0	1	10	-1520-1	1	20	-1110-0	1	18	-1610-0	1	29
-8110-0	1	26	-1520-1	1	24	-1210-0	1	18	-1610-0	1	30
			-1540-1	1	18	-1390-0	2	18	-1610-0	1	31
69-1470-0	2	12	-1540-1	2	18	-8010-0	1	18	-1610-0	1	33
-1530-0	1	12	-1600-0	1	12	-8020-0	1	18	-1610-0	2	4
-2130-0	1	26	-1640-0	1	14	-8030-0	1	18	-1610-0	2	14
-222G-0	1	12	-1800-0	1	20	-8060-0	1	18	-1610-0	2	26
-222G-0	1	26	-1830-0	1	12	-8070-0	1	18	-1610-0	3	4
-3110-0	1	12	-1830-0	1	26	-8080-0	1	18	-1620-0	1	22
-8010-0	1	10	-2080-0	1	10	-8150-0	1	18	-1620-0	1	30

From the library of: Diamond Needle Corp

Part No.	Q,ty	Page No.	Part No.	Q,ty	Page No.	Part No.	Q,ty	Page No.	Part No.	Q,ty	Page No.
84-1620-0	2	14	84-3820-0	1	31	84-5740-0	1	4	85-6240-0	1	13
-1620-0	2	16	-3820-0	1	32	-5740-0	1	4	-6280-0	2	2
-1620-0	2	29	-3820-0	1	33	-5740-0	1	8	-8010-0	1	18
-1620-0	2	30	-3830-0	1	13	-5740-0	1	10			
-1620-0	2	31	-4010-0	1	16	-5740-0	1	12	86-3110-0	1	14
-1620-0	2	32	-4010-0	2	10	-5740-0	2	25	-3110-0	2	10
-1620-0	6	26	-4130-0	1	4	-5740-0	3	24	-3140-0	1	16
-1620-1	2	28	-4130-0	1	4	-5760-0	1	14	-3150-0	2	10
-1630-0	1	28	-4130-0	1	20	-5770-0	4	24	-4110-0	1	14
-1630-0	1	29	-4620-0	1	24	-5880-0	1	26	-4110-0	2	16
-1630-0	1	30	-4620-0	2	2	-5990-0	1	10	-4110-0	2	22
-1630-0	1	31	-4620-0	2	5	-6110-0	1	20	-4110-0	2	24
-1630-0	1	32	-4640-0	1	14	-6120-0	1	14	-4110-0	3	5
-1630-0	1	33	-4640-0	2	28	-6140-0	0	14	-4110-0	4	5
-1640-0	2	25	-4640-0	2	29	-6160-0	1	18	-4110-0	5	5
-1640-0	4	14	-4640-0	2	30	-6160-0	3	16	-4120-0	1	14
-1710-0	1	4	-4640-0	2	31	-6170-0	1	10	-4120-0	1	16
-1710-0	1	33	-4640-0	2	32	-6210-0	2	10	-4130-0	1	24
-1710-0	2	4	-4640-0	2	33	-6610-0	4	13	-5010-0	1	20
-1720-0	4	20	-5110-0	1	8	-6610-0	5	2	-5010-0	2	10
-1800-0	1	33	-5110-0	2	10	-6640-0	2	2	-8510-0	1	18
-2630-0	1	26	-5110-0	2	13	-6640-0	8	2			
-3140-0	1	14	-5110-0	2	18	-7110-0	2	14	87-1360-0	1	14
-3140-0	1	29	-5110-0	2	20	-7150-0	2	24	-1430-0	1	26
-3140-0	2	24	-5110-0	2	24	-7180-0	1	16	-1560-0	2	22
-3140-0	2	26	-5210-0	1	4	-7180-0	1	16	-1610-0	2	22
-3140-0	3	28	-5210-0	1	8	-7180-0	1	18	-1710-0	4	26
-3140-0	3	30	-5210-0	1	14	-7180-0	2	12	-1890-0	3	26
-3140-0	3	31	-5210-0	2	10	-7180-0	5	25	-2630-0	1	12
-3140-0	3	32	-5210-0	2	14	-7610-0	1	14	-3110-0	1	2
-3140-0	3	33	-5210-0	2	16	-7610-0	1	16	-7260-0	1	20
-3140-0	4	2	-5210-0	2	18	-7610-0	1	26	-9010-0	4	24
-3140-0	21	2	-5210-0	2	24	-7610-0	2	2			
-3610-0	2	2	-5210-0	4	13	-7610-0	4	2	88-1360-0	1	14
-3610-0	1	4	-5210-0	5	26	-7630-0	1	2	-1360-0	1	26
-3610-0	1	4	-5610-0	1	18	-7630-0	1	24	-1760-0	2	22
-3610-0	1	10	-5620-0	1	18	-7630-0	2	6			
-3610-0	1	24	-5630-0	3	12	-7630-0	2	24	91-1060-0	32	16
-3610-0	2	4	-5640-0	1	26	-7670-0	1	16	-2660-0	1	26
-3610-1	2	8	-5640-0	2	2	-8120-0	1	18	-2670-0	1	14
-3610-0	3	8	-5660-0	2	8	-8140-0	1	14	-4060-0	2	13
-3610-0	4	4	-5660-0	2	24	-8140-0	2	10	-4110-0	1	24
-3610-0	4	25	-5660-0	2	24	-8160-0	1	14	-9010-0	1	26
-3620-0	1	24	-5660-0	3	12	-8160-0	1	16	-9020-0	1	12
-3630-0	1	14	-5660-0	4	26	-8160-0	1	18	-9030-0	1	12
-3630-0	1	20	-5660-0	10	2	-8170-0	1	18			
-3630-0	1	28	-5660-0	12	2	-8610-0	3	2	92-2300-0	2	16
-3630-0	1	29	-5670-0	1	20	-8620-0	2	2			
-3630-0	1	31	-5670-0	2	24				93-2000-0	1	18
-3630-0	3	14	-5670-0	4	16	85-1130-0	2	10	-2010-0	2	16
-3630-0	3	22	-5670-0	4	18	-1130-0	2	18	-2210-0	1	26
-3640-0	1	32	-5680-0	2	26	-1130-0	8	12	-2230-0	1	8
-3640-0	2	2	-5710-0	1	2	-1140-0	2	12	-2610-0	1	14
-3640-0	2	24	-5710-0	1	22	-1140-0	2	26	-4060-0	2	13
-3660-0	1	14	-5710-0	1	24	-1810-0	2	2	-6110-0	1	18
-3660-0	2	14	-5710-0	2	4	-1820-0	2	22	-6110-0	1	18
-3670-0	3	8	-5710-0	2	14	-2100-0	1	16	-7010-0	2	10
-3700-0	1	24	-5710-0	4	12	-2120-0	1	12	94-2140-0	3	6
-3700-0	2	22	-5710-0	5	2	-2120-0	1	18	-2310-0	2	6
-3740-0	1	4	-5720-0	2	2	-2130-0	1	10	-8010-0	1	20
-3790-0	1	14	-5720-0	2	12	-2200-0	4	2	-8020-0	2	18
-3820-0	1	28	-5720-0	5	22	-5310-0	1	8	-8100-0	1	12
-3820-0	1	29	-5730-0	1	18	-6110-0	1	32			
-3820-0	1	30	-5740-0	2	3	-6210-0	1	31			

From the library of: Diamond Needle Corp